Weston Elementary Safe Routes to School Plan



ACKNOWLEDGEMENTS

The Weston Elementary Safe Routes to School Plan was developed with the following residents and staff. Special thanks are extended to the following:

Weston Elementary Safe Routes to School Task Force

Kelly Ziegelbauer, Weston Elementary Principal, DCE
Karen Wegge, Physical Education//Health/AODA Coordinator, DCE
Jason Jablonski, Director of Buildings and Grounds, DCE
Christopher Nichols, Finance Supervisor, DCE
Yee Xiong, School Board Member, DCE
Tiffany Wurz, Mother of a DCE student
Officer Greg Schremp, Student Resource Officer, DCE
Michael Wodalski, Director of Public Works, Village of Weston

Staff for this Plan

Fred Heider, AICP, NCWRPC Planner



February 2024

Cover photo sources

This plan was developed by NCWRPC in conjunction with the D.C. Everest School District, Village of Weston, and the Weston Elementary SRTS Task Force as part of the North Central Wisconsin Regional Safe Routes to School Program. This Regional program was made possible in part by a Transportation Alternatives Program grant from the Wisconsin Department of Transportation. Additional funding provided by the NCWRPC.

For more information contact:



North Central Wisconsin Regional Planning Commission (NCWRPC)
210 McClellan St., Suite 210
Wausau, WI 54403
715-849-5510
www.ncwrpc.org



TABLE OF CONTENTS

PREFACE	1
• NCWRPC	1
• The Region	1
• Regional Livability Plan	1
• The North Central Regional Safe Routes to School Program.....	2
1. INTRODUCTION.....	4
• Purpose and Overview	4
• Why Safe Routes to School?.....	5
• Why Speed Matters	7
• People Walk	8
• Benefits of Safe Routes to School.....	9
• The 6 Es of Safe Routes to School.....	10
• Weston Elementary SRTS Planning Process	11
• Weston Elementary School Boundary	11
• Demographics Covering Weston Elementary	12
• Equity in Safe Routes to School	13
• Weston Elementary SRTS Equity Analysis	15
2. EXISTING CONDITIONS	16
• Student Tally Overview.....	16
• Parent Survey Overview	16
• Site Assessment Map.....	17
• Transportation Map	17
• Wisconsin Bike and Pedestrian Crash Analysis	18
• School Routes Map	19
• Existing Policies and Services	20
• Common SRTS Encouragement Events and Program Descriptions	23
3. SCHOOL DATA & RECOMMENDATIONS	24
• Recommendation Implementation.....	24
• Weston Elementary Data & Recommendations.....	25
• Village of Weston Recommendations.....	25

LIST OF MAPS

Map 1 – North Central Regional SRTS Program Districts 3
Map 2 – School Enrollment Boundary 40
Map 3 – Site Assessment..... 41
Map 4 – Transportation 42
Map 5 – School Routes 43
Map 6A – Recommendations 44
Map 6B – Recommendations 45

ATTACHMENTS

- A. Student Tally & Parent Survey
- B. Bicycle Crash Analysis for Wisconsin, 2006
- C. Highlights of... Wisconsin Pedestrian and Bicycle Crash Analysis, 2011-2013
- D. Adoption Documentation
- E. Bicycle Parking Guidelines

PREFACE

NCWRPC

The North Central Wisconsin Regional Planning Commission (NCWRPC) is a voluntary association of governments created in 1973 under Wisconsin State Statute 66.945, now 66.0309. NCWRPC provides assistance throughout the region in the areas of economic development, geographic information systems (GIS), intergovernmental cooperation, land use, and transportation. Staff regularly provides professional planning services to communities, for projects of both local and regional significance.



Under Wisconsin law §66.0309(9), “The regional planning commission shall have the function and duty of making and adopting a master plan for the physical development of the region”. The statute was later revised to add that the master plan must incorporate the elements described in §66.1001 – the state's comprehensive planning law. To comply with that requirement, the NCWRPC adopted the "Regional Livability Plan" in 2015.

THE REGION

The Region consists of a ten county area stretching one hundred and eighty-five miles in a north-south direction, extending from Forest and Vilas Counties in the north to Adams and Juneau Counties in the south. The Region roughly follows the upper Wisconsin River Valley and covers 9,328 square miles, or about 17 percent of the state’s total land mass.

The ten counties are: Adams, Juneau, Forest, Langlade, Lincoln, Marathon, Oneida, Portage, Wood, and Vilas. The Region includes 268 local units of government: 198 towns, 39 villages, 21 cities, and ten counties.

REGIONAL LIVABILITY PLAN

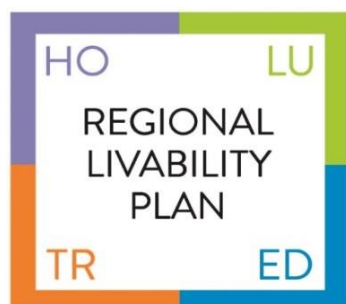

The Regional Livability Plan (RLP) of 2015 identifies ways to address the Region’s opportunities and weaknesses to become more livable for all residents. The RLP addresses four specific areas: Housing, Economic Development, Transportation, and Land Use. The RLP introduces goals, objectives, and recommendations that can help the Region use the money we have more effectively and efficiently by investing in solutions that solve multiple problems. Mainly, livable and sustainable developments are less expensive to build, require fewer municipal services, result in higher property values, and generate a range of long-term social and environmental benefits.

Working as a region, all communities can be made more livable. When residents are able to live near their place of employment, travel costs, transportation maintenance, pollution, and congestion are reduced. Efficient use of land and support for walking, biking, and access to transit reduces energy consumption saving money for individuals, communities, and the Region. The successful implementation of the RLP will save tax dollars, create more housing options, provide more transportation choices, increase economic development, accommodate an aging population, retain and attract a knowledgeable workforce, improve community health, protect the Region’s rural character, and enhance the Region’s scenic beauty.

NORTH CENTRAL WISCONSIN REGIONAL SAFE ROUTES TO SCHOOL PROGRAM

As part of NCWRPC’s on-going commitment to implement the Regional Livability Plan, the North Central Wisconsin Regional Planning Commission (NCWRPC) has created the Regional Safe Routes To School (SRTS) program. Implementing Safe Routes to School advances livability principles by making it safer and more enjoyable for people to walk and bike within their communities. The Regional SRTS program’s 2022-2025 funding period allows the NCWRPC to assist seven school districts comprised of a total of 32 school sites. See Map 1 for all districts that have entered the Regional SRTS program. This Safe Routes to School Plan document and the associated school SRTS Action Plans are an outcome of the Regional SRTS program.



To fund the program, the NCWRPC applied for and received Transportation Alternatives Program (TAP) grants from the Wisconsin Department of Transportation. Additional funding to support the grant was provided by the NCWRPC and local governments. The Regional SRTS program will provide resources and ongoing support for public and private schools, as well as communities, within the North Central Region. This regional effort will effectively leverage local funds with state funds to greatly increase Safe Routes to School programming in the Region and state.



North Central Wisconsin Regional SRTS Program Participating School Districts

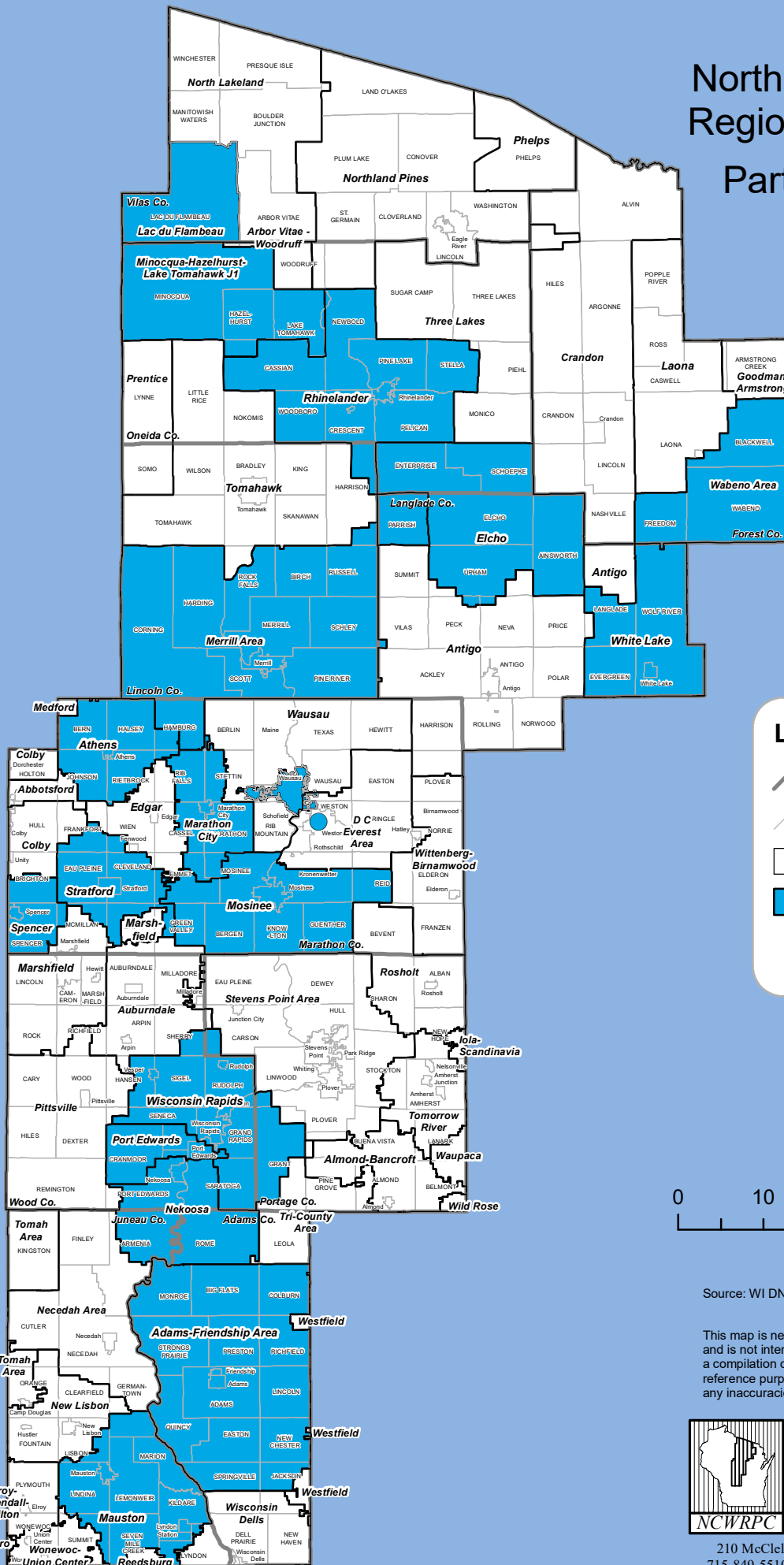

Legend

- County Borders
- Minor Civil Divisions
- School District Boundaries
- Participating Districts
- Participating School (Weston Elementary)

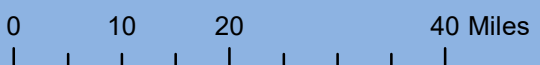

Source: WI DNR, NCWRPC

This map is neither a legally recorded map nor a survey and is not intended to be used as one. This drawing is a compilation of records, information and data used for reference purposes only. NCWRPC is not responsible for any inaccuracies herein contained.

Prepared By:

**North Central
Wisconsin Regional
Planning Commission**

210 McClellan St., Suite 210, Wausau, WI 54403
715-849-5510 - staff@ncwrpc.org - www.ncwrpc.org

CHAPTER 1: INTRODUCTION

PURPOSE AND OVERVIEW

The purpose of Safe Routes to School (SRTS) is to provide safe pedestrian and bicycle facilities that provide healthier lifestyle choices. SRTS 1) identifies physical barriers to safe walking and biking; 2) provides physical improvement ideas; and 3) provides tools for parents, students, and the community on how to safely walk and bike to school and the long lasting benefits of doing so.

Safe Routes to School (SRTS) is an international movement--and federal program--that uses programs and infrastructure to encourage children to walk and bike to school.

SRTS planning efforts 1) assess the facilities and conditions near a school; 2) examine how students are currently traveling to/from school; and 3) identify concerns/issues raised by parents, the school, and the community. Infrastructure and programming recommendations are then created for local implementation.

NCWRPC continues to be a resource for a community as they implement their SRTS Plan.

Major SRTS goals are:

1. To facilitate the planning, development, and implementation of projects and activities that will improve the safety of walking or biking to school.
2. To enable and encourage parents to allow their children, including those with disabilities, to walk and bike to school where it is safe to do so.
3. To make bicycling and walking to school a safer and fun transportation alternative, thereby encouraging a healthy and active lifestyle from an early age.

 Centers for Disease Control and Prevention
CDC 24/7: Saving Lives. Protecting People™

Office of Policy, Performance, and Evaluation



Achieving lasting impact on health outcomes requires a focus not just on patient care, but on community-wide approaches aimed at improving population health.

The CDC's Health Impact in 5 Years (HI-5) initiative highlights non-clinical, community-wide approaches that have evidence reporting 1) positive health impacts, 2) results within five years, and 3) cost effectiveness and/or cost savings over the lifetime of the population or earlier.

Safe Routes to School is one of those programs that are cost-effective and show significant population health impacts within five years.

WHY SAFE ROUTES TO SCHOOL?

Safe Routes to School is an international movement that began in Denmark in the 1970s when high student traffic deaths occurred. U.S. Congress established a nationwide SRTS program in 2005 due to high child pedestrian crash rates and rising childhood obesity rates. The whole reason for this effort is to make it safer and easier for students to walk and bike to school. Nationally, walking and bicycling to school are viewed as realistic ways for students to achieve higher levels of daily physical activity and for communities to reduce the number and speed of vehicles around schools.

Health and Obesity

- Over the past 40 years, rates of obesity have continued to steadily increase among children of all ages in the United States; and approximately 14.7 million children and adolescents—about 19.7%—are now overweight or obese. (CDC)
- Today, approximately 20% of health care costs in the United States are attributable to obesity, and health care costs just for childhood obesity are estimated at about \$14 billion per year (\$19,000 per child). (NIH)
- Less than one-quarter of children (24%) get 60 minutes of physical activity every day. (CDC)

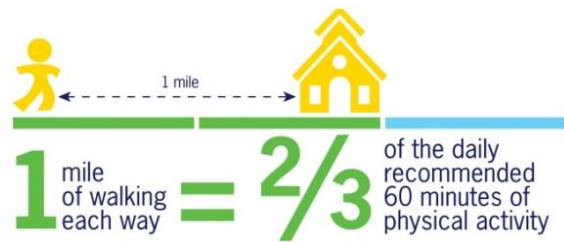

Physical Activity and Academic Performance

- Physical activity and fitness boost learning and memory in children; fitness-associated performance benefits are largest for those situations in which initial learning is the most challenging. (NIH)
- Sixth- and ninth-grade students with high fitness scored significantly better on math and social studies tests compared with less fit students, even after controlling for socioeconomic status. Muscular strength and muscular endurance were significantly associated with academic achievement in all grades. (NIH)
- Lower performing students appear to derive particular benefit from physical activity. In addition, short bicycling exercise periods resulted in enhanced neuronal activity and increased cognitive performance for teenagers with intellectual and developmental disabilities. (NIH)
- When children get physical activity before class, they are more on task and fidget less. This is true for both girls and boys, and has been shown to be particularly beneficial for children who have the most trouble paying attention and those with attention deficit disorders. (NIH)

Safety

- People walking are more than twice as likely to be struck by a vehicle in locations without sidewalks. (FHA)
- In 2020, approximately 10,400 children ages 14 and younger were injured and about 212 were killed while walking or bicycling in the United States. (NHTSA)
- Studies clearly show that higher speeds result in greater impact at the time of a crash, which leads to more severe injuries and fatalities. This is especially concerning for more vulnerable road users, such as motorcyclists, bicyclists, and pedestrians. Per vehicle miles traveled in 2019, motorcyclist fatalities occurred nearly 29 times more frequently than passenger car occupant fatalities, and 33% of motorcycle riders involved in fatal crashes in 2019 were speeding. Pedestrians made up 17% of traffic fatalities in 2019 with 6,205 fatalities. Bicyclists accounted for approximately 2% of fatalities in 2019 with 846 bicyclist fatalities. (FHA)

Traffic Congestion

- By boosting the number of children walking and bicycling, Safe Routes to School projects reduce traffic congestion around schools. (Nat'l SRTS)
- Within the span of one generation, the percentage of children that live within 1 mile of school and walked or biked to school has dropped precipitously, from approximately 89% in 1969 to just 35% in 2009. (FHA & Nat'l SRTS)
- While distance to school is the most commonly reported barrier to walking and bicycling by parents, private vehicles still account for half of school trips between 1/4 and 1/2 mile—a distance easily covered on foot or bike. (FHA)

CDC = Center for Disease Control and Prevention

NIH = National Institutes of Health

FHA = Federal Highway Administration

NHTSA = National Highway Traffic Safety Association

Nat'l SRTS = National Safe Routes to School Partnership

WHY SPEED MATTERS

There is a proven relationship between motor vehicle speeds and pedestrian safety. The average risk of death for a pedestrian upon impact from a vehicle rises as a vehicle's speed increases. Higher speeds also give both drivers and walkers less time to avoid a crash.



Source: Federal Highway Administration. Based on data from the AAA Foundation for Traffic Safety, Impact Speed and a Pedestrian's Risk of Severe Injury or Death, September 2011.



Source: FHWA.

People walk to get to places they want to go when places are nearby.

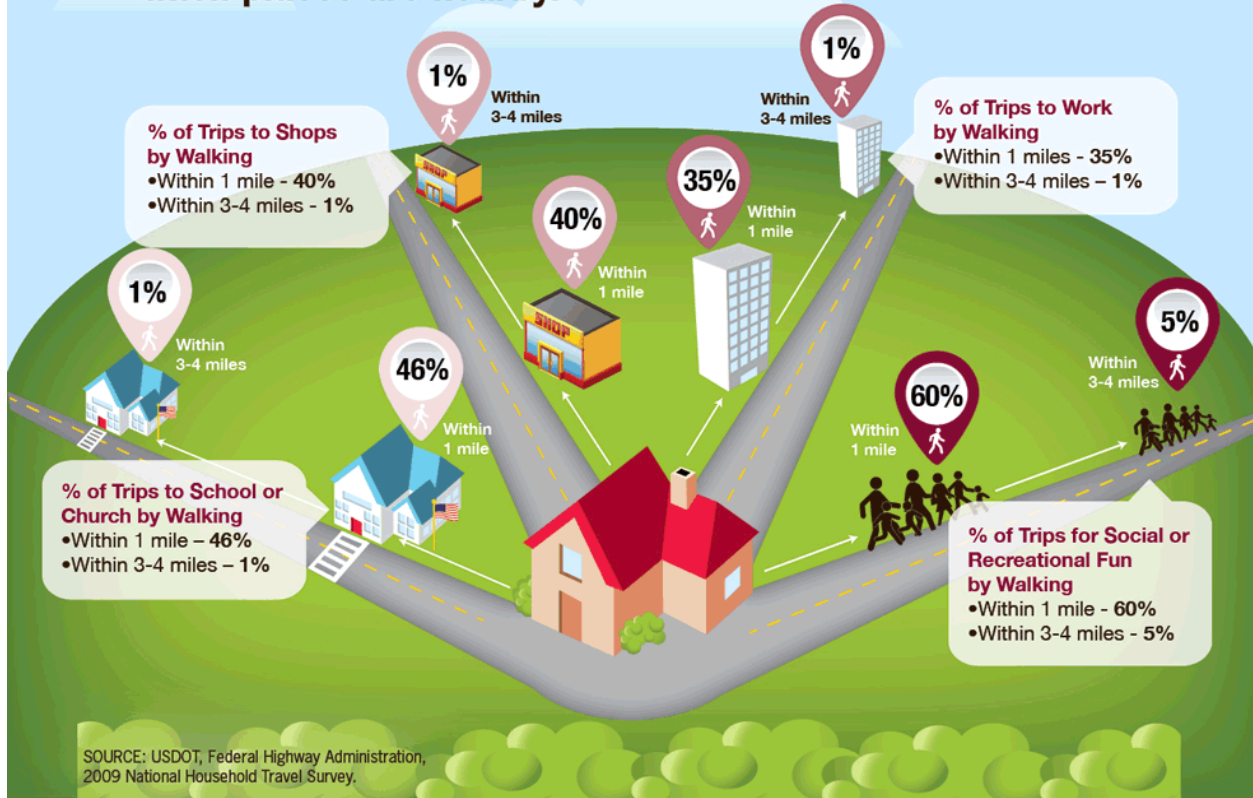

Source: USDOT, Federal Highway Administration; 2009 National Household Travel Survey.

Percentage of adults who walk

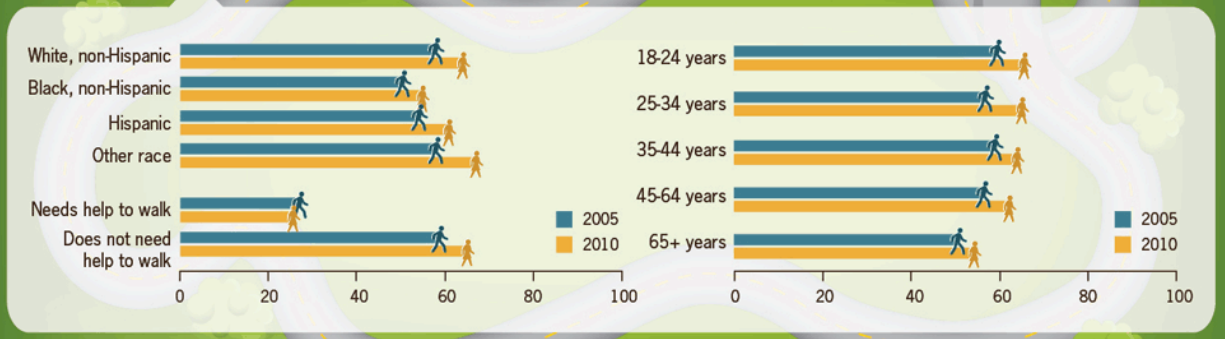

Source: CDC National Health Interview Survey, 2005, 2010.



Benefits of Safe Routes to School

Safe Routes to School improves sidewalks and street crossings and creates safe, convenient, and fun opportunities for children to bicycle and walk to and from school. The CDC has recognized Safe Routes to School as one of a handful of programs that are cost-effective and show significant population health impacts within five years. saferoutespartnership.org

COST SAVINGS

- Household savings from reduced gas & car use
- Education budget savings through reduced student busing costs



TRAFFIC SAFETY

- Reduced traffic injuries & dangers for students and community members at arrival & dismissal through street improvements near schools
- More chances to learn & practice road safety for students



CLIMATE BENEFITS AND CLEANER AIR

- Fewer student asthma attacks due to less driving & reduced air pollution results
- Cleaner air & reduced greenhouse gas emissions

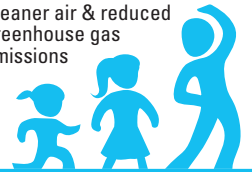

SAFETY FROM CRIME

- Increased safety from crime & violence due to more people on the streets, good lighting & better street design
- Less harassment, bullying, or violence when students walk or bike together or with adults



COMMUNITY CONNECTEDNESS

- Stronger student friendships & relationships through walking & biking together
- Positive social connections for families & neighbors



HEALTHIER STUDENTS

- Better health & stronger bones, muscles & joints through more walking & biking
- Reduced risk of chronic disease, diabetes, & obesity



SCHOOL TRANSPORTATION FIXES

- Solutions to reduced or non-existent bus service through Safe Routes to School
- Reduced traffic congestion at pick-up/drop-off times



BETTER ACADEMIC PERFORMANCE

- Better focus, improved concentration & less distraction for students who are active before school
- Fewer absences and less tardiness when students walk or bike in groups



SCHOOL

THE 6 ES OF SAFE ROUTES TO SCHOOL

Comprehensive Safe Routes to School (SRTS) initiatives have been shown to be more effective at increasing bicycling and walking to school and reducing injuries. Community members; public health, planning and transportation professionals; and school communities all have roles to play to change norms in how we move around our communities and make it appealing and safe for students to walk, bike or roll to school. The Regional Safe Routes to School program uses the 6 E's strategy as a framework for identifying needs and structuring a local SRTS program.

Education – *Providing families and the community with the skills to walk and bicycle safely.*

- A general cultural shift has increased the use of motor vehicles for short trips that easily could be done by walking or biking. **Educational** efforts include skills training among students, driver education courses, and making sure street signs and pavement markings are current and well maintained (**Engineering**).

Encouragement – *Generating enthusiasm through events, activities, and programs.*

- Encouragement strategies are about having fun; they generate excitement and interest in walking and bicycling. Encouragement activities also play an important role moving the overall SRTS program forward, because they build interest and enthusiasm, which can maintain support for changes that might require more time and resources – such as constructing a sidewalk (**Engineering**).

Engineering – *Creating physical improvements to streets and neighborhoods.*

- Engineering is the design, implementation, operation, and maintenance of traffic control devices or physical measures of roads, sidewalks, and paths. Children and adolescents need well designed paths, safe crossings, and well-maintained roads and pathways. The goal of these recommendations is to create a balanced roadway environment that can accommodate traffic, bicycles, and pedestrians of all types including those with disabilities. With regard to engineering, it is best to implement low cost solutions first and then seek funding for the larger cost-intensive projects.

Enforcement – *Working together to enforce rules for safe walking, biking, and driving.*

- Enforcement includes parents, adult school crossing guards, student patrols, school personnel, and neighborhood watch programs all working in conjunction with law enforcement to enforce rules for safe walking, bicycling, and driving.

Equity – *Ensuring that initiatives are benefiting all demographic groups and neighborhoods.*

- By prioritizing schools and neighborhoods with the highest need for safe walking and biking conditions (**Engineering**), **Education & Encouragement** programs, and **Enforcement** solutions, a higher bang-for-the-buck usually results because walking and biking are already occurring here for many trips.

Evaluation – *Assessing which approaches are more or less successful, and if they are supporting equitable outcomes.*

- Evaluation data is key to determining the scope and the success of **Education** programs; **Encouragement** events, activities, and programs; **Enforcement** solutions, **Engineering** improvements; all while making sure that results are benefiting everyone (**Equity**)

WESTON ELEMENTARY SRTS PLANNING PROCESS

This Safe Routes to School (SRTS) Plan was prepared by the North Central Wisconsin Regional Planning Commission (NCWRPC) as part of its Regional Safe Routes to School Program. This Program was made possible by an 80% Transportation Alternatives Program (TAP) grant from the Wisconsin Department of Transportation (WisDOT), with the local match coming from NCWRPC. The Village of Weston, Weston Elementary staff and D.C. Everest School District were one of 7 community & school district groups to join with the NCWRPC for TAP applications submitted in January of 2022 to WisDOT.

To make sure SRTS Plan development matches a community's and school district's needs, a SRTS Task Force is created to provide plan oversight. A SRTS Task Force is comprised of school administrators, principals, planners, law enforcement, engineers, and other Village and School District staff that also will pass an SRTS Plan through all the committees necessary to fully review and adopt the SRTS Plan for implementation.

The planning effort undertaken by the Weston Elementary SRTS Task Force and NCWRPC began with collecting and analyzing information, identifying school and community issues, and recommending steps to improve existing conditions so more walking and biking can occur.

Weston Elementary SRTS Planning Timeline

Fall/Winter 2021 – D.C. Everest School District applied with NCWRPC for SRTS Planning Grant.

Summer 2022 – WisDOT awards SRTS Planning grant.

Fall 2022 – Parent Survey & Student Tally administered in schools.

April 2023 – SRTS Task Force Mtg #1, Parent Survey & Student Tally data presented.

June 2023 – SRTS Task Force Mtg #2, Walk Audit performed around the schools.

Summer 2023 – Additional data collection, maps showing existing conditions created.

July 2023 – SRTS Task Force was emailed maps and physical recommendations for their review.

October 2023 – SRTS Task Force Mtg #3, Draft SRTS Plan presented.

Weston Elementary School Boundary

Weston Elementary is part of the D.C. Everest School District. See **Map 2** for the Weston Elementary enrollment boundary.

All grades in Weston Elementary are part of this Safe Routes to School (SRTS) Plan.

DEMOGRAPHICS COVERING WESTON ELEMENTARY

Table 1 identifies the number of residents who live within the whole Village of Weston that attend public schools (most of which will be in D.C. Everest elementary schools). This data is from the Census' American Community Survey's 5-year estimates that end on the year in the table (2010, 2015, 2021). Overall enrollment in the Village of Weston of 3 year olds and over increased and then only slightly declined (see **Table 1**). Nursery/Preschool enrollment has basically stayed the same point from a decade ago. Kindergarten enrollment substantially increased, and then returned to about the same point a decade earlier. Elementary & middle school grades both decreased substantially, with elementary enrollment surpassing the 2010 number, but high school enrollment continuing a steep decline.

Table 1: School Enrollment in Village of Weston			
	2010	2015	2021
Total 3 year olds and over enrolled in public school (mostly in D.C. Everest schools)	3,676	4,169	4,129
Nursery School/Preschool – public school	225	199	219
Kindergarten – public school	121	227	127
Elementary School (Grades 1-8) – public school	1,921	1,743	2,056
High School (Grades 9-12) – public school	920	727	687

Source: U.S. Census's American Community Survey

Table 2 shows enrollment in Weston Elementary over the last decade. Weston Elementary's enrollment is much higher in the 2015-16 and 2020-21 school years over past years.

Table 2: Enrollment			
	2010-11	2015-16	2020-21
Weston Elementary	409	538	533

Source: Department of Public Instruction

Table 3 shows The Village of Weston's population and Weston Elementary's school boundary's population in 2021 using the Census' American Community Survey. Population under 5 years identifies how many children will join their local elementary school within the next 5 years. The population of 5 to 9 year olds shows how much elementary school enrollment comes from the Village. School boundaries put this population into different elementary schools. The median ages in **Table 3** shows that the Village is slightly younger than the school boundary as a whole (see Map 2 for the school boundary).

Table 3: Population, 2021				
	Total Population	Under 5 years	5 to 9 years	Median Age
Village of Weston	15,609	765 (4.9%)	906 (5.8%)	37.1
Weston Elementary School Boundary	8,668	375 (4.3%)	354 (4.1%)	38.2

Source: U.S. Census's American Community Survey

EQUITY IN SAFE ROUTES TO SCHOOL

Equity is defined as:

"just and fair inclusion into a society in which all can participate, prosper, and reach their full potential" (various)

"freedom from bias or favoritism" (Merriam-Webster)

"the quality of being fair and impartial" (Oxford Language)

An Equity in Safe Routes to School approach challenges practices and actions that disproportionately impact and stymie the progress of certain segments of the population. These impacts can manifest in many forms, including negative health outcomes, concentrated poverty, and displacement.

For example, children in low-income communities nationwide bear the burden of the most dangerous conditions for walking and biking (Figures 1 & 2) – which discourages active transportation and leads to disproportionately high rates of walking and biking injuries.

Key Point 1:

If a local government has such a neighborhood that lacks safe walking and biking areas, then that local government should set a higher priority to fix things that would improve walking and biking conditions in that neighborhood to current standards. The local school district should make sure that the school serving that same neighborhood is a high priority for getting walking and biking education to parents.

Figure 1:

Communities with Sidewalks

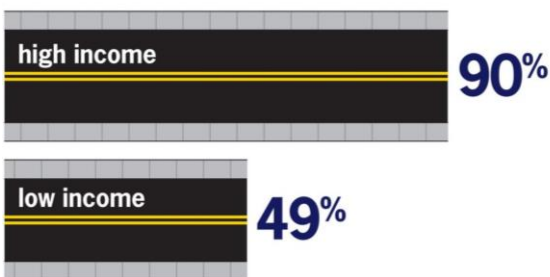

Bridging the Gap, Income Disparities in Street Features that Encourage Walking, 2012

© 2015 Safe Routes to School National Partnership

Figure 2:

Children Killed While Walking



Dangerous by Design, 2011

© 2015 Safe Routes to School National Partnership

For many residents in low-income communities, walking and biking is a main way of travel for basic needs such as food, employment, and education, as opposed to walking and biking for recreation (Figures 3 & 4). Safe places to walk and bike are a huge contributor to the vibrant fabric of any community. At the same time, walking and biking to everyday destinations in low-income communities can be very daunting when safe walking and biking are not available.

Figure 3:

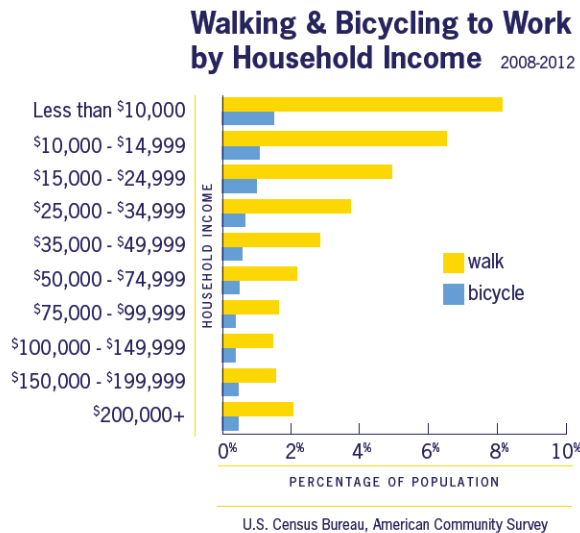

Low income Americans have the highest rates of walking and bicycling to work, and bicycling is growing most rapidly among people of color. Most transit riders are low to moderate income, and more than 60 percent walk to or from transit. The safety and convenience of walking and bicycling is vitally important for low-income people and people of color. (Census 2008-2012, Nat'l SRTS)

Figure 4:

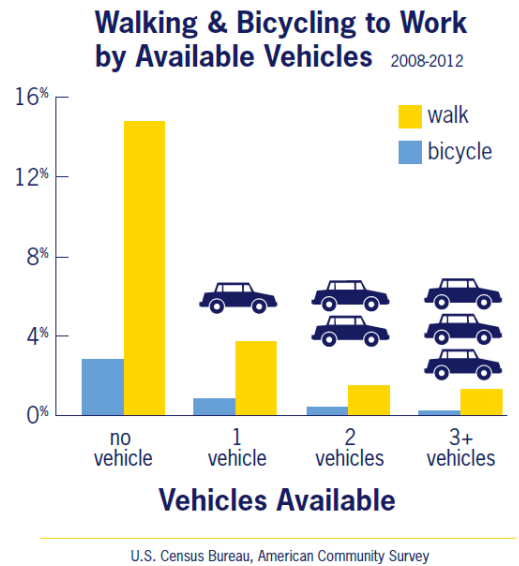

Approximately 15% of people without access to an automobile walk to work, compared to 4% for those with access to a car. Around 3% of people without access to a car bicycle to work, compared with less than a ½% of people with access to a car. People with lower incomes also report walking and bicycling to work more. Among those making less than \$10,000 per year, almost 8% walk to work and 2% bike to work, while less than 2% walk and less than a ½% bike to work among those making more than \$50,000 per year. (Census 2008-2012, Nat'l SRTS)

Key Point 2:

By prioritizing schools and neighborhoods with the highest need (low income, few or no vehicles available) for safe walking and biking conditions, and education programs, then equitable Safe Routes to School programs and infrastructure can assist with reducing inequities that may have occurred from investment decisions that funneled funds to other neighborhoods or schools within the same local government or school district.

WESTON ELEMENTARY SRTS EQUITY ANALYSIS

The Weston Elementary Safe Routes to School Equity Analysis identifies neighborhoods that would receive a higher benefit from similar resources that provide safe walking and bicycling areas than other neighborhoods.

Figure 5: U.S. DOT Equitable Transportation Community (ETC) Explorer

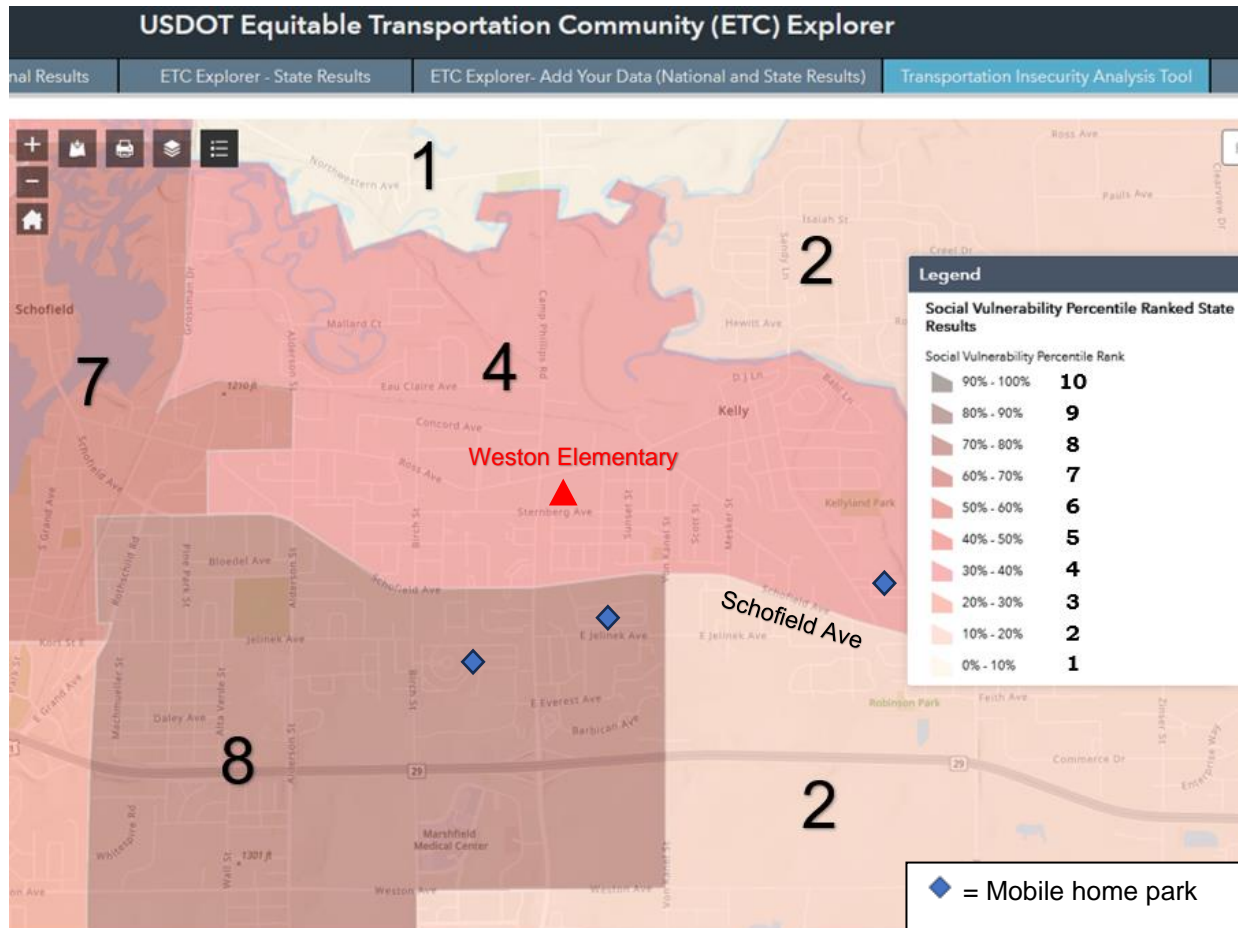

Source: U.S. Dept. of Transportation's Equitable Transportation Community (ETC) Explorer. Accessed: August 2023.

Wisconsin's Department of Transportation (WisDOT) notes that a collection of mobile homes indicates a higher priority for the Department to fund walking and biking infrastructure to connect that housing development to other locations in the same community.

In Weston, there are 3 mobile home parks near Weston Elementary, but only one is within the Weston Elementary enrollment boundary, which is north of Schofield Ave (see Figure 5 and Map 2).

Weston Elementary has a combination of a 30%-40% Social Vulnerability Rank (SVR), with parts of a 60%-70% and 70%-80% SVR per the USDOT's ETC Explorer (see Figure 5).

CHAPTER 2: EXISTING CONDITIONS

This chapter analyzes a range of background material and information used to help develop the recommended safe routes to school strategies, including: a review of the results of the student travel tallies and parent surveys conducted as part of this Plan; discussion of information gleaned from the planning meetings and site assessments; and background information on the planning area including policies and practices that are in place, as well as traffic and crash data.

STUDENT TALLY OVERVIEW

In the fall of 2022, student tallies were administered by most homeroom teachers in Weston Elementary. The **student tally** (3-day Students Arrival and Departure Tally Sheet) from the National Safe Routes To School Center was used (See Attachment A). In the student tally, homeroom teachers documented how students traveled to and from school and had the opportunity to note other relevant comments.

Student tallies occurred over a two-day period, so one student could equal four trips if they attended school both days. However, it is possible that some students attended only one day due to illness or absence.

Student tally results for Weston Elementary are shown in **Figure 7** on the following pages.

PARENT SURVEY OVERVIEW

While student tallies were being coordinated at school, parent surveys were sent home to be completed by parents. The **Parent Survey** from the National Safe Routes To School Center was used (See Attachment A). On the form, parents identified how children got to and from school, distance from school, total travel time, and factors that influence their decision to allow or keep their children from walking/biking to and from school. Additionally, they were asked if they thought walking/biking is fun and healthy and to what degree they felt that the school encouraged walking/biking.

Parents were instructed to fill out only one survey per school. If multiple children attended the same school, they were asked to fill out one survey for the child with the next birthday from that day's date.

Parent survey results for Weston Elementary are shown in **Figures 8-10** on the following pages.

SITE ASSESSMENT MAP

As part of this Safe Routes to School planning process, a walking and bicycling audit was conducted within a few blocks Weston Elementary. NCWRPC staff and the Weston Elementary SRTS Task Force walked the area around the school, discussed how students arrive and leave school, and identified any concerns about current walking and biking conditions near the school. Audit results are shown on **Map 3 (Site Assessment)**.

A walk & bike audit is an activity where participants observe and assess how pedestrians and bicyclists can navigate travel along a street and through intersections in a particular area.

TRANSPORTATION MAP

Map 4 (Transportation) shows the most current traffic volume counts within about a half mile radius of each school. It also details pedestrian and bicycle crashes that have occurred between 2010 and 2020 within about a half mile radius of the school.

Safety, traffic volume, and traffic speed are generally top reasons parents report as why they don't allow their child to walk or bike to school more often. Creating a safer environment for these activities is an important factor that requires an understanding of safety issues and proven actions that can be taken to improve safety.

Traffic counts are reported as the number of vehicles expected to pass a given location on an average day of the year. This value is called the **annual average daily traffic** or AADT and is represented on traffic count or traffic volume maps. The AADT is based on a short duration traffic count, usually 48 hours, taken at the location. This count is then adjusted for the variation in traffic volume throughout the year and the average number of axles per vehicle. Short duration counts are collected over three, six, or 10-year cycles at more than 26,000 rural and urban locations throughout the state.

Traffic crashes – Traffic safety experts have moved away from the term “accident” in favor of the term “crash” to describe a collision. WisDOT made this change in 1990 because traffic crashes are not accidents, but avoidable events caused by a single variable or chain of variables. Crashes involving motor vehicles that result in injuries or fatalities to bicyclists and pedestrians have been recorded at the state and federal levels for many years.

Crash data is reported universally in Wisconsin on form DT4000. A reportable crash is one that results in injury or death of any person, damage to government owned property of \$200 or more, or private property damage of \$1,000 or more. *However, it is important to highlight some shortcomings:*

1. *Some studies indicate that as few as 10% of all bicycle cashes are reported;*
2. *Some roads with a higher frequency of bicycle crashes may have higher bicycle use;*
3. *Very likely that there will be no detectable pattern of bicycle crashes because of the small number reported in rural areas and small cities.*

Children ages 4 to 6 have little concept of how fast cars are traveling, or how to anticipate what a driver is going to do, so it is up to adults to be responsible.



NHTSA

WISCONSIN BIKE AND PEDESTRIAN CRASH ANALYSIS

A bicycle crash analysis that was performed for Wisconsin in 2006 (**Attachment B**) has some major findings that directly affect pedestrian and bicycle planning for Weston Elementary:

- “Four out of the top five crash types indicate that the motorist made the critical error. This may indicate that motorists are not fully aware of bicyclists on the roadway and that increased education is necessary.”
- “Many bicycle–vehicle crashes had similar characteristics. A large concentration of crashes occurred within one of, or a combination of, the following environments: in an urban city, at an intersection, or on an urban city street or arterial roadway. Eighty-three percent of crashes occurred in a city (MV4000 Report), 93.6% of crashes occurred in an urban area (MV4000 Report), 65.7% of crashes occurred at an intersection (PBCAT), 71.7% of crashes occurred on a city street (MV4000 Report), and 56.1% of crashes occurred on an arterial street.”
- The city of Madison has a low average crash rate based on bicycle miles traveled. A scattering of other cities – Appleton, Green Bay, and Wausau also have relatively low average crash rates based on bicycle miles traveled, but none of these communities come close to the total bicycle miles traveled as demonstrated by Madison.
- Bicycle–vehicle crashes are almost twice as common during workweek days than on the weekend days. The majority of workweek crashes occur during the a.m. and p.m. peak travel hours. The lower number of crashes occurring on weekends may indicate that recreational bike trips occur more frequently on recreational trails or low volume roadways where exposure is less.

In 2015, WisDOT commissioned a pedestrian and bicycle crash analysis (**Attachment C**) which also have some major findings that directly affect walking and bicycle planning in Weston:

Overall Trends in Wisconsin Pedestrian and Bicycle Safety

- “Higher levels of walking and bicycling were associated with greater pedestrian and bicyclist safety: between 2006 and 2013, the number of people walking and bicycling to work increased and the risk of pedestrian and bicyclist fatalities and injuries (per commuter) decreased.”
- Of fatal traffic crashes reported between 2011 and 2013, approximately 10% involved pedestrians and 2% involved bicyclists. Approximately 9% of total trips were made by pedestrians and 1% were made by bicyclists, so these travel modes were overrepresented in fatal crashes.
- The highest concentrations (“hot spots”) of fatal and severe-injury pedestrian and bicycle crashes tend to be along signalized, multilane, arterial roadway corridors in urban and suburban areas with moderate to high levels of pedestrian or bicycle activity. Without controlling for pedestrian and bicycle volumes (or other measures of exposure), it is not possible to determine if these locations experienced more crashes simply because they had more activity or because their conditions were inherently more dangerous. Regardless, these types of locations warrant attention due to high numbers of crashes.

Strategies to Improve Pedestrian and Bicycle Safety (Attachment C)

Engineering Strategies

- “Reduce roadway design speeds (e.g., reduce the number of lanes, narrow roadway lanes).”
- “Reduce roadway crossing distances.”
- “Provide pedestrian and bicycle facilities (e.g., sidewalks, paved shoulders, and bicycle lanes).”
- “Improve roadway lighting.”

See “Why Speed Matters” on page 7.

See **Attachment C** for additional strategies in Education, Enforcement, & Evaluation.

SCHOOL ROUTES MAP

A school routes map in this plan was developed to visualize where walking and biking students could travel to and from school. These routes may not be the most direct routes to walk or bike to school, but they identify where important safe crossings are provided. School Routes are shown on **Map 5** (School Routes).

Through map development, places may become apparent where adult crossing guards, sidewalks, painted crosswalks, signage, and traffic signals should be provided or maintained. In order to identify the optimal routes to school as well as problem areas, it is necessary to conduct an assessment of the physical environment surrounding the school and particular intersections blocks away from a school that cross busy streets.

School routes maps identify routes that are as direct as possible to encourage more walking and biking to school.
Note: Routes are for planning purposes and may not be safe to use now.

The **school boundary** on the map identifies a geographic zone within which a student is assigned to attend that designated school. The full school enrollment boundary is on **Map 2**.

The **1-mile walk distance** on the map was created using a computer to walk or bike 1-mile based upon the existing road and path network and limiting factors such as a railroad track or river.

EXISTING POLICIES AND SERVICES

County Road X Corridor Plan

This is an extensive plan for the County Road X corridor from Ross Ave south to Weston Ave that was adopted in 2017. Map 2 in this Corridor Plan identifies proposed Ped / Bike Enhancements that apply to getting kids to school. This plan recognizes that Weston Elementary is a community asset and:

“To support the School, the village wishes to preserve the integrity, safety, and family-friendliness of the single-family residential neighborhood to its south, and promote reinvestment and redevelopment in the largely rental, multiple family area to its west across Camp Phillips Road.”

Therefore, the Village supports safe walking and biking from the surrounding neighborhoods to Weston Elementary.

Weston Sidewalk Policy

Generally, 1) original sidewalk construction and repaired or replaced sidewalk costs shall be borne by the Village when included as part of a Village-initiated project. 2) Developers are responsible for sidewalk costs when instructed to install them. 3) Repaired or replaced sidewalk costs shall be borne by the adjacent owner. The owner abutting a sidewalk shall remove snow and ice within 48 hours. See the Village ordinance for details.

School Busing

Generally, D.C. Everest School District’s school bus policy provides transportation for these situations:

- Student resides more than two miles from school.
- For Grades K-9, a student must reside at or beyond 1/2 mile.
- Student resides in an area identified in the District's Unusually Hazardous Transportation Plan.
- Special needs student with transportation that is arranged by Pupil Services consistent with IEP.

According to Wisconsin law, a K-12 public school student living more than two miles from a public school is entitled to busing provided by the School District. Additionally, §121.5(9)(a), Wis. Stats., establishes procedures to develop an unusually hazardous transportation (UHT) plan within a two mile radius of each school. An “unusual hazard” is an existing transportation condition that constitutes more than an ordinary hazard and seriously jeopardizes the safety of pupils traveling to and from school. If a hazard is found, then it is documented in a UHT plan, and the student is offered school busing.

D.C. Everest School District has an active UHT plan, and **UHT Elementary Zones for Weston Elementary** are (also see Figure 6):

Hazardous Area	Hazard
Area 3 Schofield Avenue (Hwy JJ) From Business 51 Grand Avenue and Schofield Avenue Intersection to Club House Rd.	Heavy truck and auto traffic throughout the day. Continuous sidewalks do not exist and there are no crossing guards <i>Affects students living south of Schofield Ave.</i>
Area 12 Ross Avenue From Business 51 to Timber St.	Heavy truck and auto traffic throughout the day. Continuous sidewalks do not exist and there are no crossing guards. <i>Affects students living north of Ross Ave.</i>

Area 15 Birch Street From Ross Ave to Schofield Ave.	Children would be exposed to heavy auto traffic throughout the day and has no crossing guards. <i>Affects students living west of Birch St.</i>
Area 16 Timber Street From Ross Ave to Sternberg Ave	This area has no sidewalks and has no crossing guards. <i>Affects students living east of Timber St.</i>
Area 17 Sternberg Avenue From Timber St to Von Kanel St.	This area has no sidewalks and has no crossing guards. <i>Affects students living north of Sternberg Ave.</i>
Area 18 Von Kanel Street From Sternberg Ave to Schofield Ave	This area has no sidewalks and has no crossing guards. <i>Affects students living east of Von Kanel St.</i>

Figure 6: UHT Zone for Weston Elementary



Yellow area = UHT Zone

General Policy on Walking and Biking

Weston Elementary has the following policies: Students who walk, ride a bicycle, or skate to school will be dismissed at the end of the day after all buses have left. Students who ride bicycles to school are to practice good safety habits at all times. Helmets should be worn. Bicycles are to be walked to and from the bicycle rack area and off school grounds. Violation of this rule may result in the loss of the privilege of bringing a bicycle to school. The school is not responsible for the damage or theft of bicycles.

Bike Racks

Bike racks at Weston Elementary are located along the western school sidewalk, but not by the main entrance. The Site Assessment map shows where bike racks are located. Similar to most schools in Wisconsin, all of the bike racks need updating, because they don't allow a bike frame to be supported at two points to hold it up while locked, and to allow a U-lock to secure the frame and front tire to the bike rack (See rack guidance in **Attachment F**).

Crossing Guards

Map 3 shows an adult crossing guard assists students crossing CTH X at Sternberg Avenue.

Adult crossing guards are usually assigned at heavily traveled intersections. The presence of crossing guards can significantly increase safety for youth by ensuring that they are learning and obeying pedestrian safety rules as they cross the street under their watch.

Safety Patrols

Safety Patrol provides an opportunity for many young people to demonstrate their public service and leadership potential. The program promotes safety awareness and provides protection for children as they travel to and from school. A student in the Safety Patrol program at their school is assigned to one corner of an intersection, and is taught how to keep other children on the sidewalk safe from traffic. Safety Patrol students are only placed at intersections with an adult present. See **Map 3** for their locations.

Walking and Bicycling Education

Education is an important component of improving the safety of bicyclists, pedestrians, and motorists alike through skills development. Education is one of the 6 E's strategies of a multi-faceted approach to reduce pedestrian and bicycle crash risk, with the other E's being Engineering, Encouragement, Equity, Enforcement, and Evaluation.

Current Weston Area walking and bicycle education includes:

1. Each summer the Everest Area Optimist Club hosts a Bike Rodeo at the Weston Public Safety Building. The event challenges participants in a number of riding skills, bike knowledge, and safety. Prizes are given in three age groups to the riders who demonstrate knowledge and skills at the highest level.
2. SAFE KIDS Marathon County, led by Aspirus Health, hosts bike helmet fittings, free helmet distributions, and bike safety skills demonstrations at various community events every year.
3. www.BicycleWausau.org – Wausau MPO website with bike routes, trails, and education.
4. In summer, residents place: "Give 3-feet" yard signs in front yards from Wisconsin Bike Fed.

Walking and Bicycling Encouragement

Encouraging people of all ages and abilities to walk and bicycle requires varying degrees of information, support, and persuasion. Encouragement is one of the 6 E's strategies of a multi-faceted approach to reduce pedestrian and bicycle crash risk, with the other E's being Engineering, Education, Equity, Enforcement, and Evaluation.

Current Weston Area walking and bicycle encouragement includes:

- There are many 5K run/walk events that happen every year in Weston.
- Multiple gatherings in Weston are held year round to build community and inadvertently promote walking to and among the events.
- Multiple independent and big box stores supply walking and bicycling gear.

COMMON SRTS ENCOURAGEMENT EVENT AND PROGRAM DESCRIPTIONS



Walk and Roll to School Day (fall), and Bike and Roll to School Day (spring) – A national event (<https://www.walkbiketoschool.org/>) that is created locally at a school with nationally branded materials to encourage walking, biking, or rolling to school on this one occasion. Once a person has walked, rolled, or biked to school, then they may ask questions that lead to continuing to walk, bike, or roll to school.

Walking School Bus Program – A group of children who walk to school together under the supervision of a trained route leader.

See the 2-page guide, "Starting a Walking School Bus: The Basics," that is available on <https://www.ncwrpc.org> and searching for "Safe Routes Resources."



Frequent Walker/Biker Program – This could be designed in a number of ways to encourage walking/biking to school; or at school during lunch/recess, with trinket rewards after so many times participating.



Safe Routes Partnership – The Safe Routes Partnership is a national nonprofit organization working to advance safe walking and rolling to and from schools and in everyday life, improving the health and well-being of people of all races, income levels, and abilities, and building healthy, thriving communities for everyone.

They share success stories from around the nation in their blog, through a resource library, and webinars.

NOTE – Many other programs, and the creation of new programs, are happening throughout the nation all the time.

1 = Source for Walking School Bus graphic is <https://zerofatalitiesnv.com/>

CHAPTER 3: SCHOOL DATA & RECOMMENDATIONS

This chapter presents possible solutions to address the issues and opportunities observed by SRTS Task Force members, and NCWRPC staff throughout the development of this Plan.

- Each school's data starts this chapter, with each school's recommendations following.
- Communitywide recommendations follow all the school sections.

Comprehensive Safe Routes to School initiatives have been shown to be more effective at increasing walking and biking to school and reducing injuries.

The SRTS Task Force and NCWRPC have developed the following recommendations on the six E's principals of Safe Routes to School programs (further defined on page 9):

Education – Providing families and the community with the skills to walk and bicycle safely.

Encouragement – Generating enthusiasm through events, activities, and programs.

Engineering – Creating physical improvements to streets and neighborhoods.

Enforcement – Working together to enforce rules for safe walking, biking, and driving.

Equity – Ensuring that initiatives are benefiting all demographic groups and neighborhoods.

Evaluation – Assessing which approaches are more or less successful, and if they are supporting equitable outcomes.

CDC research discovered that three low-cost strategies are associated with schools that have a higher percentage of students who walk or bike to school:

- 1 of 3 - Having crossing guards;
- 2 of 3 - Having bicycle racks; and
- 3 of 3 - Providing promotional materials to students and families.

RECOMMENDATION IMPLEMENTATION

The following guidance for how soon a recommendation could occur is listed by each specific recommendation:

- Short-term (less than 2 years)
- Medium-term (2 to 5 years)
- Long-term (more than 5 years)

Responsible party identifies who may act on this recommendation with **the lead party in bold**.

Italicized words (i.e., *Engineering*, *Encouragement*, *Education*, *Equity*, *Enforcement*, and *Evaluation*) in the following recommendations identify which of the E's initiatives a recommendation relates to.

Weston Elementary served 532 students (2022-2023) in Kindergarten through 5th grades.

- **Main modes of travel by Weston Elementary students:**
 1. School Bus (47% morning & 56% afternoon)
 2. Family Vehicle (48% morning & 39% afternoon)

Number of students living within 1-mile of school: 132 (25%).

Distance eligibility for riding a bus: beyond 1/2 mile (K-9).

Number of students eligible for a bus ride: 467 (88%).

Number of students eligible for busing due to a hazard situation: 23 (4%).

Table 4		Weston Elementary Morning & Afternoon Travel Comparison					
	Walk	Bike	School Bus	Family Vehicle	Carpool	Transit	Other
Morning	3%	0.3%	47%	48%	0.7%	0	0.3%
Afternoon	4%	0.1%	56%	39%	0	0	0.5%

Source: Student Tally, October 2022

The discrepancy between morning and afternoon travel in Table 4 & Figure 7 shows that 9% more parents are driving their kids to school in the morning vs. afternoon. All except 1% of those students take the bus home and the 1% walks home. Percentages don't total 100% due to rounding.

Figure 7: Weston Elementary Student Tally Results Morning and Afternoon Travel Comparison

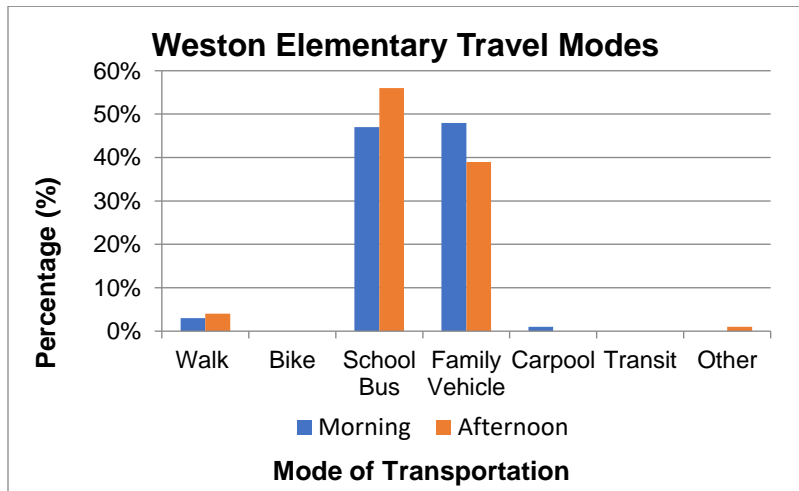

Source: Student Tallies, October 2022

Weston Elementary Parent Survey Results

156 surveys received.

Parents were instructed to fill out only one survey per school. If multiple children attended the same school, they were asked to fill out one survey for the child with the next birthday from that day's date.

Among parents who answered the survey, 55 of 156 students live within 1-mile of school - with only 5 students (3%) walking, and none biking to school (see Figure 8). About 46% of students represented in this parent survey took the school bus, which is slightly less than the student tally (51.5%).

By comparing student arrival in the parent survey vs. the student tally, it appears that parent survey results show a similar representation as the student tally. These are not statistical results but should be used to assess the general mood of parents from Weston Elementary.

FIGURE 8: How does your child arrive and depart from school?

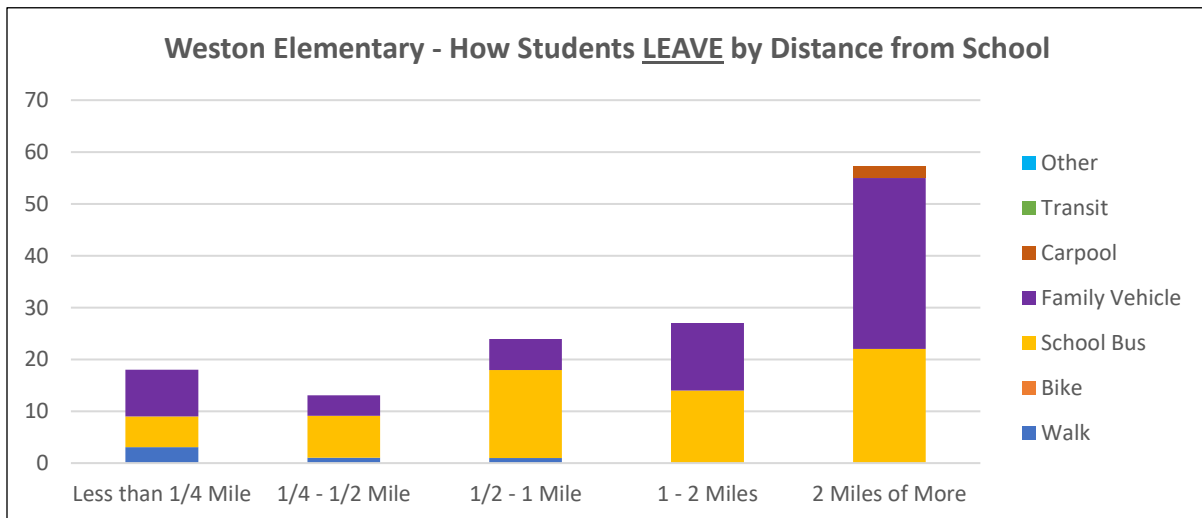
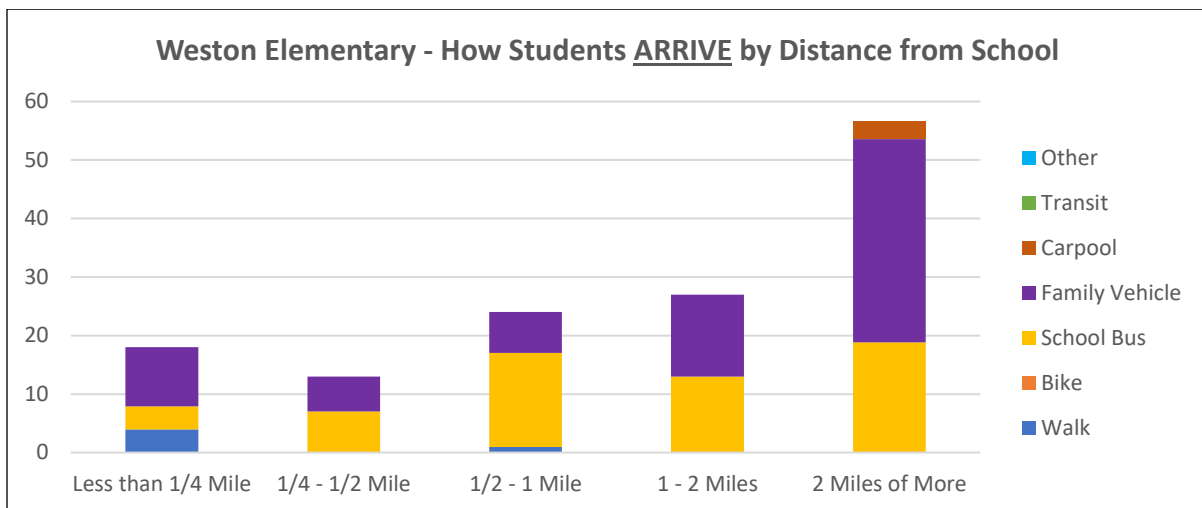

Source: Parent Surveys, October 2022

FIGURE 9: Has your child asked to walk?

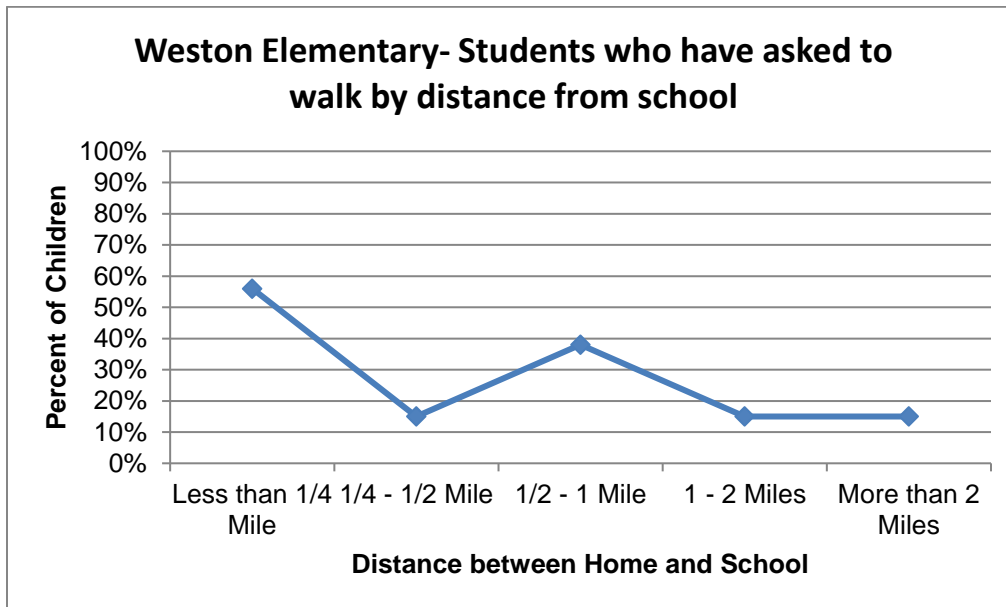

Source: Parent Surveys, October 2022

From Weston Elementary's October 2022 Parent Survey

Parent's opinion about how much their **child's school encourages/discourages** walking/biking to/from school:

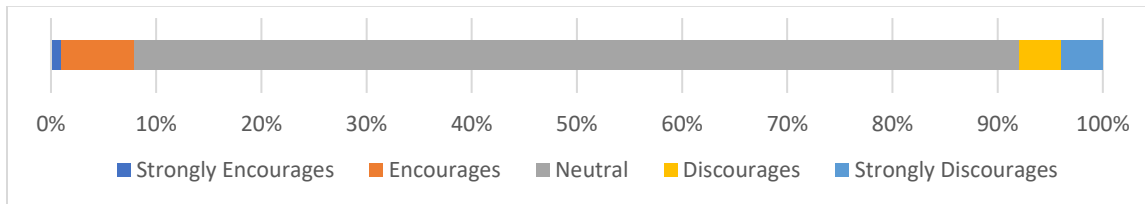

Parent's opinion about **how much fun** walking and biking to/from school is for their child:

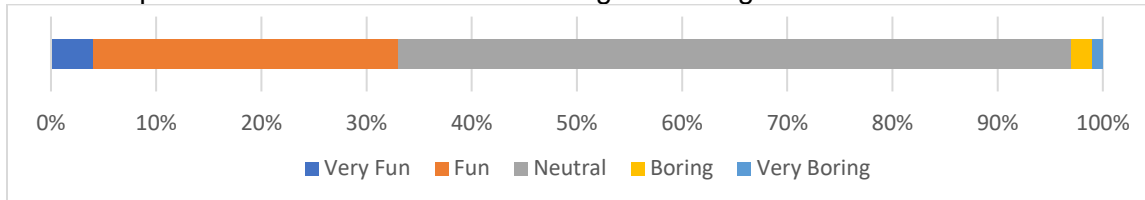

Parent's opinion about **how healthy** walking and biking to/from school is for their child:

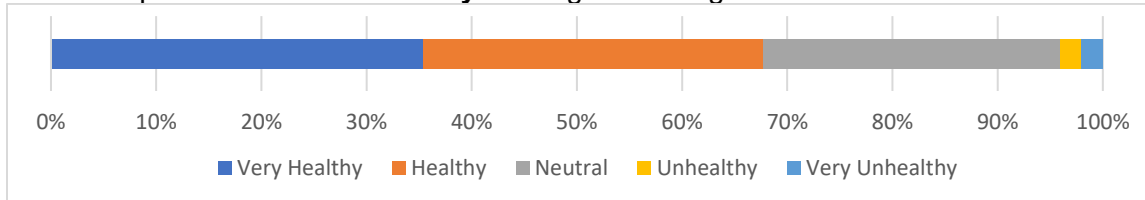
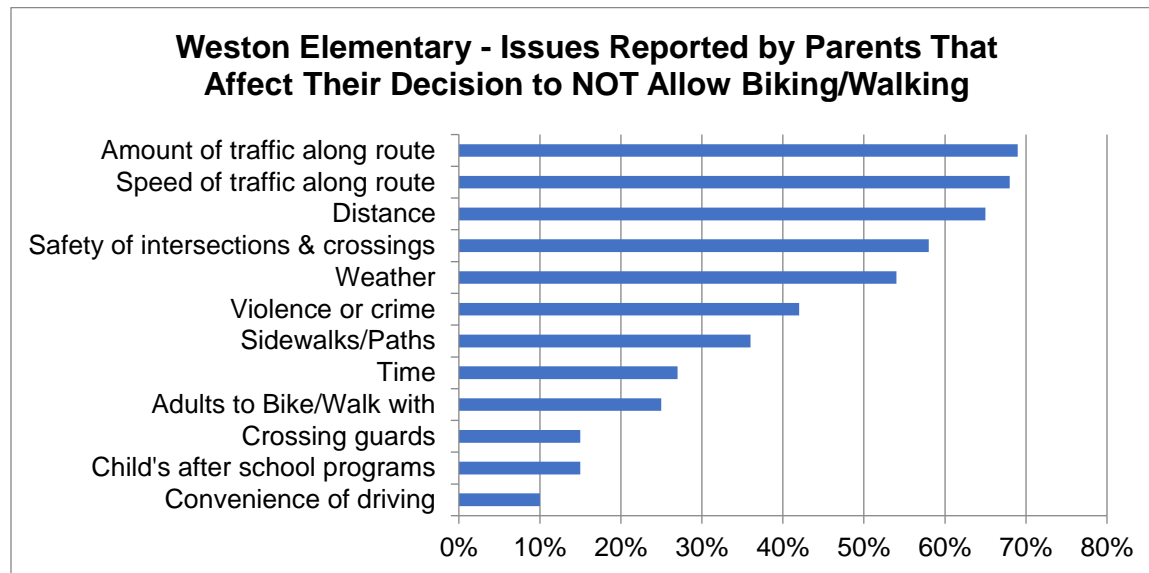

FIGURE 10: What of the following issues affect your decision to NOT allow walking or biking?



Source: Parent Surveys, October 2022

Existing Policies and Services for Weston Elementary Students

Current walking and biking policies and programming at Weston Elementary include:

- Bike & Roll to School Day encouragement event (see table below).

School	WALK & ROLL TO SCHOOL DAY (Fall)	BIKE & ROLL TO SCHOOL DAY (Spring)
Weston Elementary		2018

Crossing Guards

Adult crossing guards are assigned by the Everest Police Department to the intersection of Camp Phillips Rd and Sternberg Ave for Weston Elementary students. See **Map 3**.

Safety Patrol

Students in the Safety Patrol program are assigned to assist at the Camp Phillips Rd and Sternberg Ave crosswalks, with additional students by the circle drive entrance. See **Map 3**.

Bike Racks

Bike racks are located on the west side of Weston Elementary. The main areas where students would ride from are the south through the south parking lot, and from the east. A second set of bike racks should be near the main entrance to serve students that arrive from the east, and for visitors to the school. Site Assessment **Map 3** shows where bike racks are located.

Similar to most schools in Wisconsin, all of the bike racks need updating, because they don't allow a bike frame to be supported at two points to hold it up while locked, and to allow a U-lock to secure the frame and front tire to the bike rack (See rack guidance in Attachment E).



Weston Elementary – Maps

Site Assessment Map

As part of this Safe Routes to School planning process, a walking and bicycling audit was conducted within a few blocks around the school. Walk and bike audit results are shown on **Map 3** (Site Assessment).

Transportation Map

Map 4 (Transportation) shows the most current traffic volume counts within about a half mile radius of the school. It also details pedestrian and bicycle crashes that have occurred between 2010 and 2020 within about a half mile radius of the school. A *Wisconsin Bike and Pedestrian Crash Analysis* exists along with strategies to improve pedestrian and bicycle safety on pages 18-20.

School Routes Map

A map of potential school routes was developed to visualize where walking and biking students could travel to and from school. These routes may not be the most direct routes to walk or bike to school, but they identify where important safe crossings are provided. School Routes are shown on **Map 5** (School Routes).

Recommendations for Weston Elementary

NOTE – There are additional recommendations that apply to the school that are listed in the Village of Weston Recommendations section following these recommendations.

Map 6B – “School Grounds” box *Engineering*

Short-term Responsible party: **School Dist., Village.**

Recommendation: Connect campus sidewalk on south side of building to Camp Phillips Rd sidewalk.

Short-term Responsible party: **School Dist., Village.**

Recommendation: Connect campus sidewalk on south side of building through parking lot to Sternberg Ave sidewalk.

Short-term Responsible party: **School Dist.**

Recommendation: Install white Stop line 9-feet in advance of Sternberg Ave sidewalk at all three driveways, and move Stop signs back to Stop lines. This will reinforce to drivers that stopping before encroaching upon the sidewalk is key to keeping pedestrians safe. The Stop sign for the driveway furthest to the east could be on a movable base and moved to the grass when snow plowing season begins, and returned to the asphalt location in spring.

Short-term Responsible party: **School Dist.**

Recommendation: Replace all bike racks with new racks that allow front tire & bike frame to be locked. As the need arises add scooter racks and skateboard racks. Place at least one new bike rack in an area adjacent to the main entrance. See bike rack guidelines in Attachment F.

Short-term Responsible party: **School Dist.**

Recommendation: Consider adding a bike repair station by loop drive off of Camp Phillips.

Review "Update Community & School Parents..." recommendation when completing each of these recommendations.



Encourage Walking and Biking *Education & Encouragement*

Traffic increases near schools because parents are driving their kids to school instead of allowing them to walk or bike. This flow of traffic increases the likelihood of a variety of traffic incidents that includes crashes, speeding, illegal parking, and failure to yield the right of way. It also decreases the likelihood that students are motivated to walk or bike to school or that parents will allow them to do so.

The “Resources” webpage has various support materials for a successful Safe Routes To School program. Go to: <https://www.ncwrpc.org> and search for Safe Routes Resources.

Short-term

Responsible party: School Dist.

Recommendation: Advertise that the “Nat’l SRTS–Teaching Kids To Walk Safely (by age)” document exists to parents before each school year to assist them with teaching their child to walk safely to school if they wish.



Short-term

Responsible party: **School Dist.**, Village.

Recommendation: Consider annually participating in Walk and Roll to School (fall) or Bike and Roll to School (spring). School and Village may need to cooperate if additional temporary crossing guards or traffic cones are needed on these special **day or week long** events.

Whether addressing the need to make walking and biking safer for children and youth or encouraging them to be more active, Walk Bike & Roll To School events can be a powerful tool to start, grow and sustain change. Events can celebrate good things, put a light on neglected issues, galvanize community support, or even start advocacy. They can be particularly good at helping all stakeholders to come together and experience what is working, what isn't, and how to collaborate to fix what is broken.

Go online here (<https://www.walkbiketoschool.org/>) to:

- Plan and register an event;
- Get resources for your event; and
- Learn who else is participating and more.

Short-term

Responsible party: School Dist.

Recommendation: Consider linking to WisDOT's *Pedestrian safety* and *Bicycling safety* websites on the School website.

Short-term Responsible party: Village, School Dist.

Recommendation: Consider bringing established bicycle safety training to Weston and possibly co-advertise this training via School and Village newsletters (regardless of location or sponsorship as long as the event is open to the public; if only available to school families, then Village would not advertise event).

Medium-term Responsible party: **School Dist.**, WI Bike Fed.

Recommendation: Consider increasing bicycle education in Weston Elementary by cooperating the School District to 1) train staff to become bicycle education trainers (usually PE teachers are trained); and 2) acquire a fleet of bicycles, helmets, and a trailer for the bike fleet, so bicycling education can move to various schools within the School District or to various locations for training. Contact the WI Bike Fed to Train the Trainer.

Note: Under the Village's Recommendation: "Community-wide Bicycling Education" the Wausau MPO (which the Village is a member) may decide to buy a bike fleet for local school district use.

Short-term Responsible party: School Dist.

Recommendation: Consider creating a walking/biking club whereby students get punch cards and token rewards for walking and biking to school. This potential program could be expanded to include walking laps around the school grounds during the school day.

School Bus Policy *Evaluation*

Families are dis-incentivized to allow walking or biking through the School District's bussing policy. By providing a school bus ride for such short distances in urban areas, the School District is suggesting that most urban residential streets are not safe to walk or bike.

Short-term Responsible party: School Dist.

Recommendation: Consider revising school bus policy to allow walking without a bus being provided in the Village of Weston until these distances are met:

- For Pre-K & Kindergarten, all are bussed but stop may be up to 1/2 mile from home with parental accompaniment.
- For Grades 1-3, beyond 1 mile.
- For Grades 4-12, beyond 2 miles.

Note: A review of each incorporated municipality that hosts a DCE school needs to be reviewed before a blanket school bus policy change is made. There may need to be a separate part in the policy that is specific to each municipality based upon a traffic analysis near each school.

Measure if Engineering and Education Efforts are Working *Evaluation*

A variety of recommendations have been made to work toward creating Safe Routes to School for Weston Elementary. However, it is imperative that Student Tallies and other measurement tools are utilized **as needed** to determine if the implemented recommendations have been effective. In this way, the Task Force can continue to make new observations and recommendations to help work toward the goal of creating safe routes for the students in the community.

The “Resources” webpage has various support materials for a successful Safe Routes To School program. Go to: <https://www.ncwrpc.org> and search for Safe Routes Resources.

Short-term Responsible party: School Dist., Village.

Recommendation: After a series of recommendations have been implemented, then consider conducting student tallies to determine how effective at changing behavior those recommendations worked.

If walking and biking have not increased, then review why and make changes to the educational programming or physical infrastructure or any other change as needed.

Short-term Responsible party: Village.

Recommendation: Consider conducting a traffic study as necessary on Camp Phillips Rd in front of Weston Elementary to determine if additional countermeasures are needed to slow down traffic.

Village of Weston Recommendations

All of the following recommendations are within the Village of Weston limits, but various parties may be responsible for implementation.

NOTES – 1) There are additional recommendations that apply to the Village that are listed in the Weston Elementary Recommendations section. 2) Use the WMUTCD for all signage recommendations. 3) Consult Marathon County Highway or WisDOT to coordinate recommendations that are suggested for county or state highways.

Sidewalks *Engineering*

Sidewalks exist sporadically on major roads in Weston. The Weston SRTS Task Force and NCWRPC identified additional locations for some sidewalks.

Medium-term Responsible party: Village.

Recommendation: Add sidewalks per Maps 6A & 6B. **Equity:** To serve those who may walk more than others for transportation purposes, consider completing projects that serve a mobile home park first. Any projects along a school route (Map 6) from the mobile home park to school qualifies as serving this neighborhood.

Short-term Responsible party: Village.

Recommendation: While waiting to install sidewalks on Sternberg Ave per Map 6A, consider painting an “urban shoulder” white line, 8-9 feet off the curb face on both sides of the road, and consider installing “walk facing traffic” and “bike with traffic” signs. The urban shoulder and “bike with traffic” sign are useful for all of Sternberg Ave. This would provide a shared space to allow on-road parking and also provide a space to walk (where no sidewalk exists) or bike out of the main travel lanes.



Source: Iheartorangecountyny (Facebook)

Review "Update Community & School Parents..." recommendation when completing each of these recommendations.

Map 6A – “Camp Phillips Rd” box *Engineering*

Short to long-term Responsible party: **Village**, Marathon County Hwy.

Recommendation: Add a pair of double sided Rectangular Rapid Flash Beacons (RRFBs), or Pedestrian Hybrid Beacons, School Crossing signs on the north side of Sternberg Ave school crosswalk, and possibly add a pedestrian refuge island, and possibly reduce curb radii on all 4 corners.

Short-term Responsible party: Village, **Marathon County Hwy.**

Recommendation: At Sternberg Ave intersection, re-paint all crosswalks and Stop lines exactly the same as the high visibility crosswalks and Stop lines at Ross Ave and Camp Phillips Rd.

Short-term Responsible party: **Village**, Marathon County Hwy.

Recommendation: Install a second street light on southeast corner of Sternberg Ave & Camp Phillips Rd, facing west.

Review "Update Community & School Parents..." recommendation when completing each of these recommendations.

Map 6A – “Camp Phillips Rd” box at the bottom of the map *Engineering*

Short-term Responsible party: Village, **Marathon County Hwy.**

Recommendation: Paint “SCHOOL X-ING” at least 100-feet in advance of the Sternberg Ave school crosswalk.

Short-term Responsible party: Village, **Marathon County Hwy.**

Recommendation: Add Higher Fines signs to School Zone signs.

Short-term Responsible party: Village, **Marathon County Hwy.**

Recommendation: Install School Zone Ends and Speed Limit signs on the same post at the end of School Zone.

Short-term Responsible party: **Village**, Marathon County Hwy.

Recommendation: Paint “shark teeth” yield triangles 30-feet in advance of Sternberg Ave school crosswalk; and install Yield To Pedestrians School paddle sign on road centerline at “shark teeth.”

Review "Update Community & School Parents..." recommendation when completing each of these recommendations.

Map 6A – “Camp Phillips Rd & Ross Ave Intersection” box *Engineering*

Short-term Responsible party: Village, **Marathon County Hwy.**

Recommendation: Continue painting existing high visibility crosswalks and Stop lines as is.

Short-term Responsible party: Village, **Marathon County Hwy.**

Recommendation: Re-paint regular crosswalks as high visibility crosswalks, and move Stop lines for re-painted crosswalks to same distance as existing high visibility crosswalks.

Review "Update Community & School Parents..." recommendation when completing each of these recommendations.

Map 6B – “School Grounds” box *Engineering*

Short-term Responsible party: **School Dist.**, Village.

Recommendation: Connect campus sidewalk on south side of building to Camp Phillips Rd sidewalk.

Short-term Responsible party: **School Dist.**, Village.

Recommendation: Connect campus sidewalk on south side of building through parking lot to Sternberg Ave sidewalk.

Short-term Responsible party: School Dist.

Recommendation: Install white Stop line 9-feet in advance of Sternberg Ave sidewalk at all three driveways, and move Stop signs back to Stop lines. The Stop sign for the driveway furthest to the east could be on a movable base and moved to the grass when snow plowing season begins, and returned to the asphalt location in spring.

Short-term Responsible party: School Dist.

Recommendation: Replace all bike racks with new racks that allow front tire & bike frame to be locked. As the need arises add scooter racks and skateboard racks. Place at least one new bike rack in an area adjacent to the main entrance. See bike rack guidelines in Attachment F.

Short-term Responsible party: School Dist.

Recommendation: Consider adding a bike repair station by loop drive off of Camp Phillips.

Review "Update Community & School Parents..." recommendation when completing each of these recommendations.

Short-term Responsible party: Village.

Recommendation: Re-paint regular crosswalk as high visibility crosswalk.

Short-term Responsible party: Village.

Recommendation: Install an in-street Yield to Pedestrians School paddle sign in center of road, 8-feet east of school crosswalk; **or** only during arrival and pick-up, place 2 reflective traffic cones in center of road, 8-feet in advance of both sides of school crosswalks on Sternberg Ave.

Short-term Responsible party: Village.

Recommendation: Since no sidewalk exists on south side of Sternberg Ave, then install an in-street Yield to Pedestrians School paddle sign 6-feet off curb face on west side of crosswalk to create pedestrian refuge area in crosswalk.

Short-term Responsible party: Village.

Recommendation: Add a street light to cover crosswalk.

Review "Update Community & School Parents..." recommendation when completing each of these recommendations.

Crossing Guards *Enforcement & Education*

The Village has an adult crossing guard program, which is run by the Police Department. Adult crossing guards are usually assigned at heavily traveled intersections. The presence of crossing guards can significantly increase safety for youth by ensuring that they are learning and obeying pedestrian safety rules as they cross the street under their watch.

Short-term Responsible party: Village.

Recommendation: Continue an adult crossing guard program to serve school crossings that need extra attention in the Village.

Short-term Responsible party: Village.

Recommendation: Consider adding crossing guards to the following intersections:

- Birch St & Sternberg Ave;
- Timber St & Sternberg Ave;
- Van Kanel St & Sternberg Ave; and
- Ross Ave & Camp Phillips Rd.

Community-wide Bicycling Education *Education*

There are several school districts in the metro area with Weston that have or will have Safe Routes To School plans. All of these districts are determining their own ways to implement bicycle education within their schools. There are many home-schooled and parochial school students that could also benefit from such bike education.

Medium-term Responsible party: Wausau MPO, **Village, School Dist.**, WI Bike Fed, NCWRPC

Recommendation: Wausau MPO to possibly partner with the Wisconsin Bike Fed to provide bicycle education services to the greater MPO community and to local school districts. Bicycle education strategies could include programs to train physical education teachers, provide annual educational events and programs (like Bike & Roll To School Day/Week), or provide other support or assistance to schools within the Wausau MPO.

This may be an opportunity to support establishing a Wisconsin Bike Fed employee in the Central Wisconsin area for more hands on support for school districts and local governments to become more bike friendly.

Note: Under the School's Recommendation: "Encourage Walking and Biking" the School District may decide to buy a bike fleet for local school district use.

Encourage Walking and Biking *Education & Encouragement*

Traffic increases near schools because parents are driving their kids to school instead of allowing them to walk or bike. This flow of traffic increases the likelihood of a variety of traffic incidents that includes crashes, speeding, illegal parking, and failure to yield the right of way. It also decreases the likelihood that students are motivated to walk or bike to school or that parents will allow them to do so.

The "Resources" webpage has various support materials for a successful Safe Routes To School program. Go to: <https://www.ncwrpc.org> and search for Safe Routes Resources.

Short-term Responsible party: Village

Recommendation: Consider linking to WisDOT's Pedestrian safety and Bicycling safety websites on the Village website.

Short-term Responsible party: Village, School Dist.

Recommendation: Consider bringing established bicycle safety training to Weston and possibly co-advertise this training via School and Village newsletters (regardless of location or sponsorship as long as the event is open to the public; if only available to school families, then Village would not advertise event).



Short-term

Responsible party: **School Dist.**, Village.

Recommendation: Consider annually participating in Walk and Roll to School (fall) or Bike and Roll to School (spring). School and Village may need to cooperate if additional temporary crossing guards or traffic cones are needed on these special **day or week long** events.

Whether addressing the need to make walking and biking safer for children and youth or encouraging them to be more active, Walk Bike & Roll To School events can be a powerful tool to start, grow and sustain change. Events can celebrate good things, put a light on neglected issues, galvanize community support, or even start advocacy. They can be particularly good at helping all stakeholders to come together and experience what is working, what isn't, and how to collaborate to fix what is broken.

Go online here (<https://www.walkbiketoschool.org/>) to:

- Plan and register an event;
- Get resources for your event; and
- Learn who else is participating and more.

Camp Phillips Road Speeding *Enforcement & Engineering*

Camp Phillips Rd speed limit is 25 mph between Schofield Ave and Ross Ave. In the summer of 2023, a speed study was performed on Camp Phillips Rd at about Sternberg Ave. The results showed an 85th percentile speed of traffic as 37-39 mph – **more than 10 miles over the speed limit.**

There is no way for an officer to be stationed on Camp Phillips Rd at all times; but the design speed of the road could be reduced to make the road feel like driving 25 mph is the right speed.

See “Why Speed Matters” on page 7 of this plan.

Short-term Responsible party: **Village**, Marathon County Hwy.

Recommendation: To make drivers aware of the existing 25 mph speed limit, make the following improvements to Camp Phillips Rd’s 25 mph speed limit zone:

- Install extra large speed limit signs at both ends of this stretch of Camp Phillips Rd.
- Increase the amount of speed limit signs on this stretch of Camp Phillips Rd.
- If needed, paint “25 MPH” in both lanes at the start of both ends of this speed limit zone.
- If needed, install temporary digital speed feedback signs at different locations within this speed limit zone, and move the signs every 3 weeks when used.

Medium-term Responsible party: **Village**, Marathon County Hwy.

Recommendation: If the 85th percentile speed of traffic on Camp Phillips Rd at about Sternberg Ave does not become 25 mph after the above recommendations, then investigate what countermeasures to employ on Camp Phillips Rd.

Update Community & School Parents After Recommendation Installed *Education*

Each of the *engineering* recommendations in this plan is designed to national standards and therefore can stand on its own. In order to get faster understanding of the new traffic pattern, new device, or policy change, community education will provide the critical mass that will then through their actions teach the rest of the traveling public how to react.

Short-term Responsible party: **School Dist., Village**, Local large employers.

Recommendation: After a recommendation in this SRTS Plan is completed, consider if the public would benefit from a newsletter article teaching them about the new traffic pattern, new road device, or new policy, and then create and publish a newsletter article if warranted.

The Village has a newsletter, the School has a newsletter, and large employers in the area may also have newsletters. If an engineering recommendation is completed that warrants an article, then the Village’s engineer would write the article for Village, School, and large employer use. If a school policy is changed that affects the whole community, then the School would write the article for School, Village, and large employers to use. Websites are another use for these articles, but newsletters go to each client individually whether by mail or email.

Measure if Engineering and Education Efforts are Working *Evaluation*

A variety of recommendations have been made to work toward creating Safe Routes to School for Weston Elementary. However, it is imperative that Student Tallies and other measurement tools are utilized **as needed** to determine if the implemented recommendations have been effective. In this way, the Task Force can continue to make new observations and recommendations to help work toward the goal of creating safe routes for the students in the community.

The “Resources” webpage has various support materials for a successful Safe Routes To School program. Go to: <https://www.ncwrpc.org> and search for Safe Routes Resources.

Short-term Responsible party: School Dist., Village.

Recommendation: After a series of recommendations have been implemented, then consider conducting student tallies once in a school year to determine how effective at changing behavior those recommendations were.

Note: Make sure that community education occurs before Student Tallies are conducted. See recommendation: “Update Community & School Parents After Recommendation Installed.”

If walking and biking have not increased, then review why and make changes to the educational programming or physical infrastructure or any other change as needed.

Short-term Responsible party: Village.

Recommendation: Consider conducting a traffic study as necessary on Camp Phillips Rd in front of Weston Elementary to determine if additional countermeasures are needed to slow down traffic.

Annual SRTS Plan Review *Evaluation*

No plan operates in a vacuum with unlimited resources. There are annual cost constraints that every school and government needs to weigh the benefits of.

Short-term Responsible party: **School Dist., Village, NCWRPC**

Recommendation: Choose a committee to work on implementing this plan.

Short-term Responsible party: **School Dist., Village, NCWRPC.**

Recommendation: Annually review this Weston Elementary SRTS Plan’s recommendations when preparing annual budgets and annual operations procedures.



If costs are too high to budget for a particular recommendation in a given year, then consider how low cost projects may be accomplished instead. Hosting annual Walk & Roll or Bike & Roll to School day/weeks keeps the momentum going for changes that take time.

NCWRPC continues to be a resource for the whole community as you implement this SRTS Plan.

Map 2 Enrollment Boundary Weston Elementary

Weston Elementary
Safe Routes To School

Legend

-  Weston Elementary
-  Minor Civil Division
-  Water

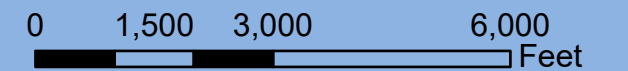
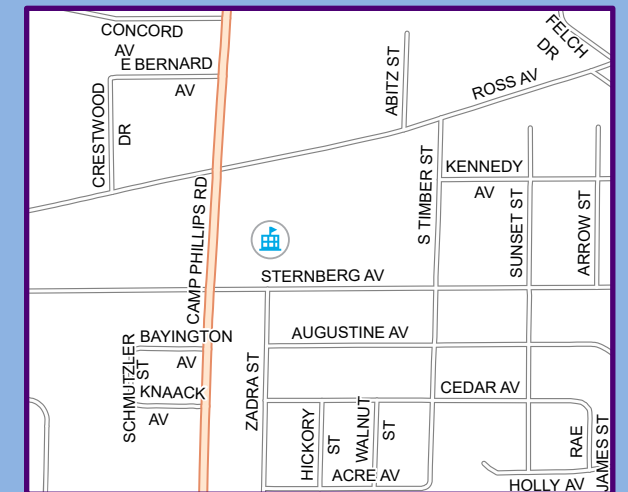

Source: WI DNR, WisDOT, NCWRPC, Village of Weston
This map is neither a legally recorded map nor a survey and is not intended to be used as one. This drawing is a compilation of records, information and data used for reference purposes only. NCWRPC is not responsible for any inaccuracies herein contained.



Prepared By:
**North Central
Wisconsin Regional
Planning Commission**

210 McClellan St., Suite 210, Wausau, WI 54403
715-849-5510 - staff@ncwrpc.org - www.ncwrpc.org

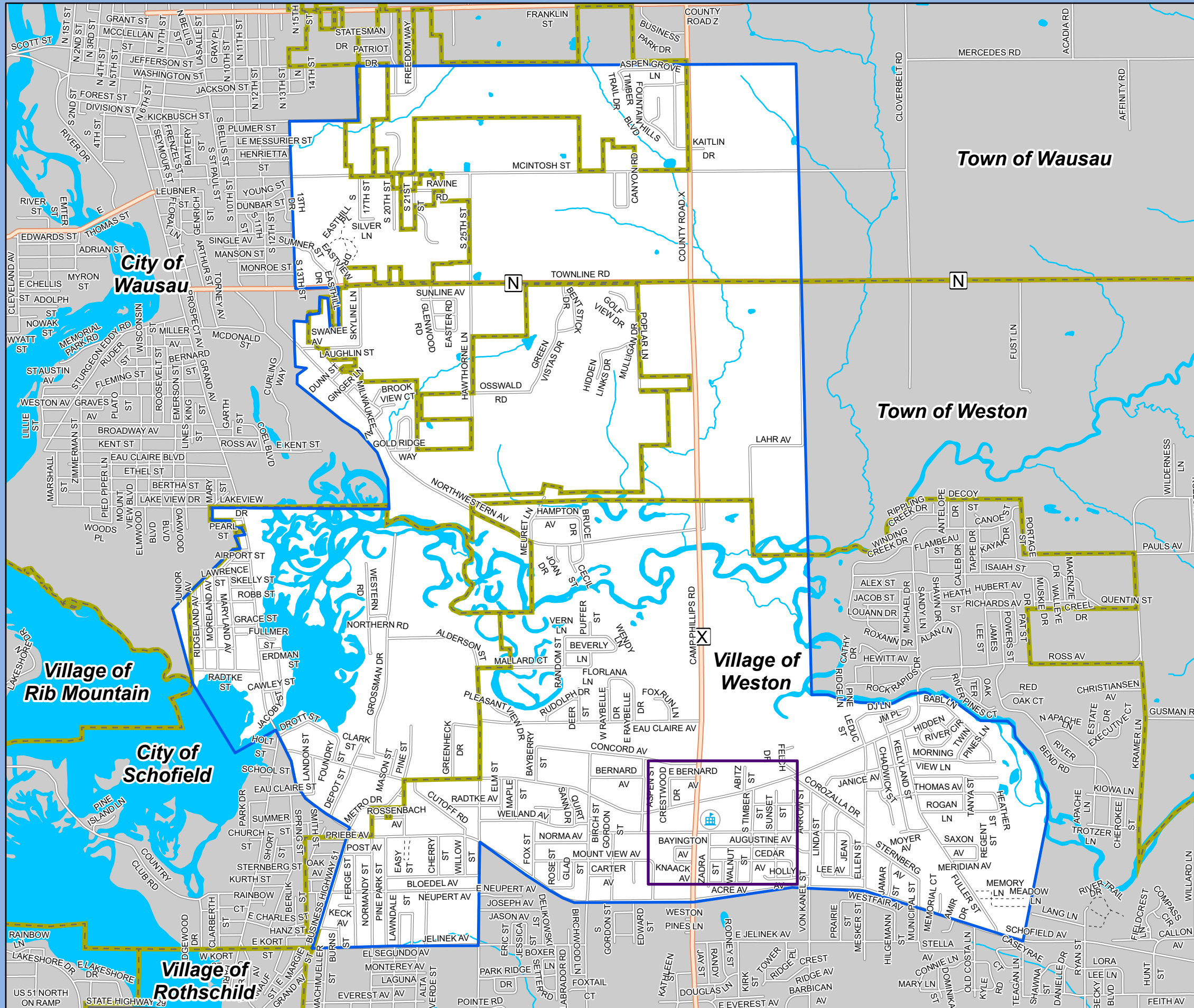













Map 3 Site Assessment

Weston Elementary

Weston Elementary
Safe Routes To School

Legend

-  Weston Elementary
-  School Entrance
-  Bike Rack
-  Crossing Guard
-  Safety Patrol
-  Speed Feedback Sign
-  Traffic Light
-  School Crossing
-  Sidewalk
-  Fence
-  Gate
-  15 MPH School Speed Limit (Includes Higher Fine Zone)
-  High Visibility Crosswalk

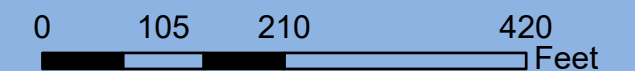

Source: WI DNR, WisDOT, NCWRPC, Village of Weston
This map is neither a legally recorded map nor a survey and is not intended to be used as one. This drawing is a compilation of records, information and data used for reference purposes only. NCWRPC is not responsible for any inaccuracies herein contained.



Prepared By:
**North Central
Wisconsin Regional
Planning Commission**

210 McClellan St., Suite 210, Wausau, WI 54403
715-849-5510 - staff@ncwrpc.org - www.ncwrpc.org

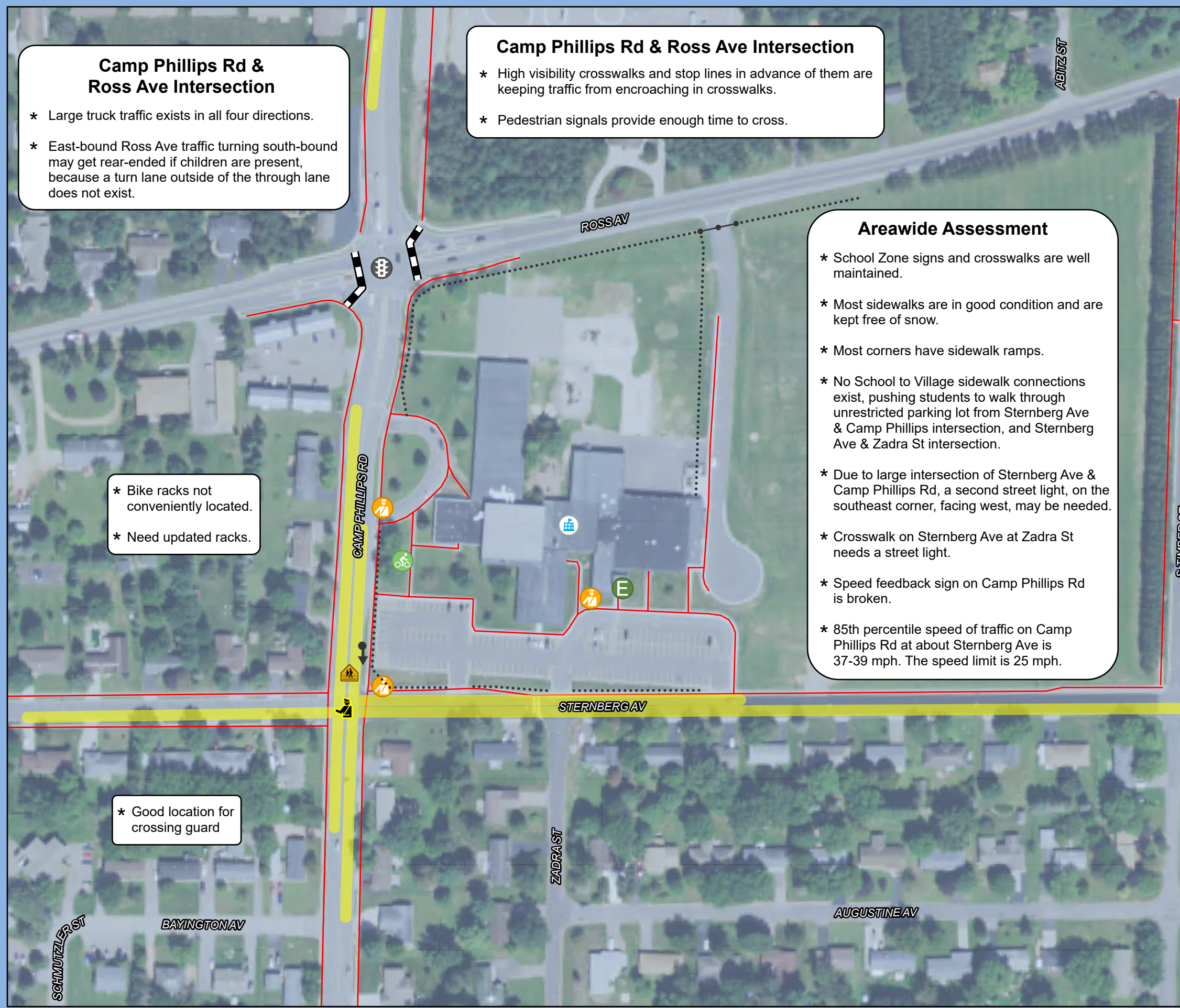

Camp Phillips Rd & Ross Ave Intersection

- * Large truck traffic exists in all four directions.
- * East-bound Ross Ave traffic turning south-bound may get rear-ended if children are present, because a turn lane outside of the through lane does not exist.

Camp Phillips Rd & Ross Ave Intersection

- * High visibility crosswalks and stop lines in advance of them are keeping traffic from encroaching in crosswalks.
- * Pedestrian signals provide enough time to cross.

Areawide Assessment

- * School Zone signs and crosswalks are well maintained.
- * Most sidewalks are in good condition and are kept free of snow.
- * Most corners have sidewalk ramps.
- * No School to Village sidewalk connections exist, pushing students to walk through unrestricted parking lot from Sternberg Ave & Camp Phillips intersection, and Sternberg Ave & Zadra St intersection.
- * Due to large intersection of Sternberg Ave & Camp Phillips Rd, a second street light, on the southeast corner, facing west, may be needed.
- * Crosswalk on Sternberg Ave at Zadra St needs a street light.
- * Speed feedback sign on Camp Phillips Rd is broken.
- * 85th percentile speed of traffic on Camp Phillips Rd at about Sternberg Ave is 37-39 mph. The speed limit is 25 mph.

- * Bike racks not conveniently located.
- * Need updated racks.













- * Good location for crossing guard

Map 4 Transportation

Weston Elementary

Weston Elementary
Safe Routes To School

Legend

-  Weston Elementary
 -  U.S. Highway
 -  State Highway
 -  Main Roads
 -  Local Roads
 -  15 MPH School Speed Limit
 -  Higher Fine School Zone
 -  Sidewalks
 -  Traffic Counts
 -  Speed Limit
- Crash Type (2010-2023)**
-  Bicycle
 -  Pedestrian
 -  Both

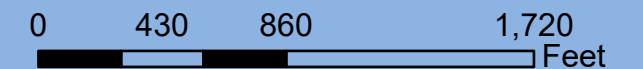

Source: WI DNR, WisDOT, NCWRPC, Village of Weston
This map is neither a legally recorded map nor a survey and is not intended to be used as one. This drawing is a compilation of records, information and data used for reference purposes only. NCWRPC is not responsible for any inaccuracies herein contained.



Prepared By:
**North Central
Wisconsin Regional
Planning Commission**

210 McClellan St., Suite 210, Wausau, WI 54403
715-849-5510 - staff@ncwrpc.org - www.ncwrpc.org











Map 5 School Routes

Weston Elementary

Weston Elementary
Safe Routes To School

Legend

-  Weston Elementary
-  School Boundary
-  Feeder Route
-  Main Route
-  1-Mile Walk Distance
-  U.S. Highway
-  State Highway
-  Main Roads
-  Local Roads

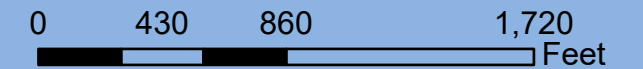

Source: WI DNR, WisDOT, NCWRPC, Village of Weston
This map is neither a legally recorded map nor a survey and is not intended to be used as one. This drawing is a compilation of records, information and data used for reference purposes only. NCWRPC is not responsible for any inaccuracies herein contained.



Prepared By:
**North Central
Wisconsin Regional
Planning Commission**



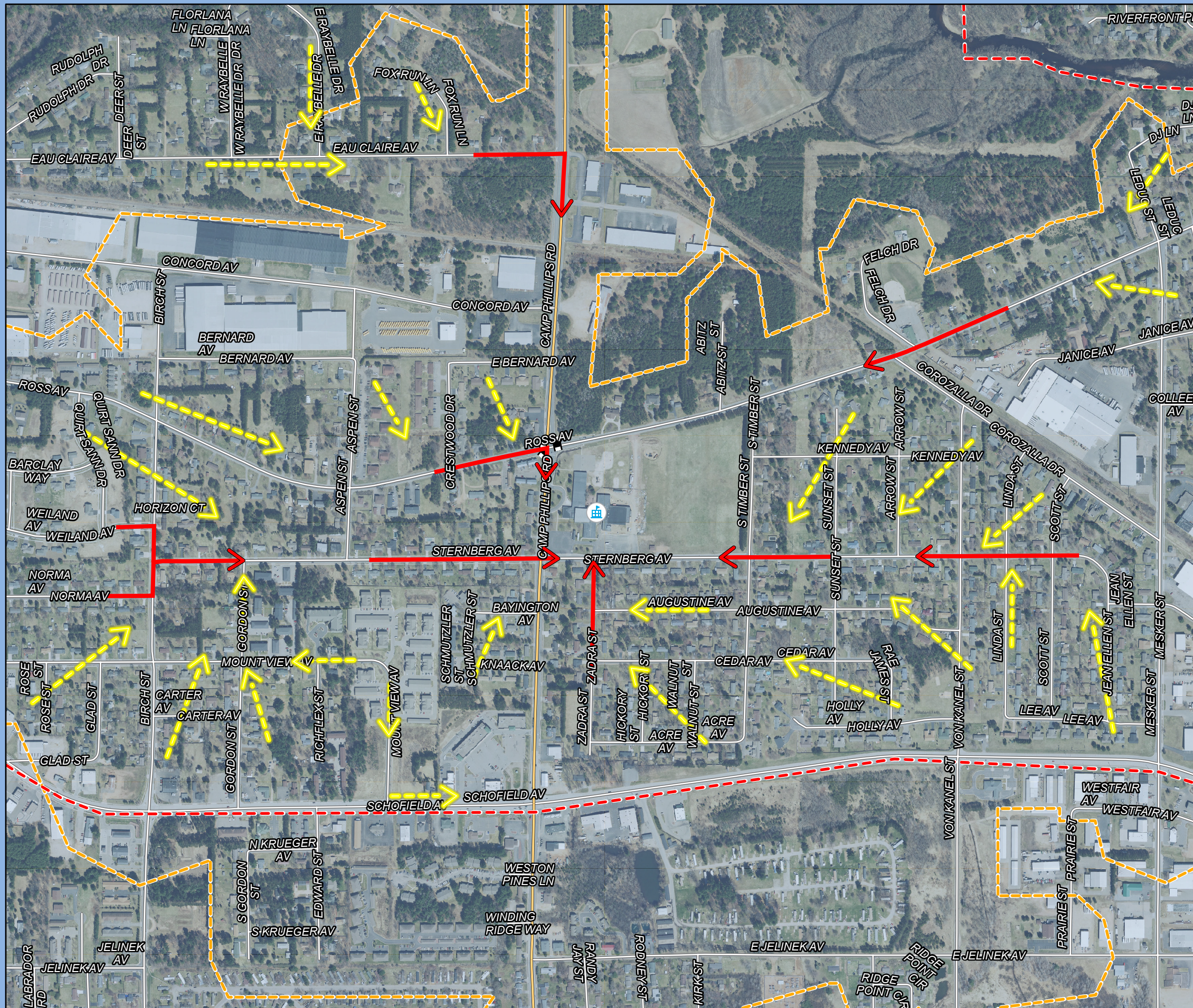





210 McClellan St., Suite 210, Wausau, WI 54403
715-849-5510 - staff@ncwrpc.org - www.ncwrpc.org



Map 6A Physical Recommendations Weston Elementary

Weston Elementary
Safe Routes To School

Legend

-  Weston Elementary
 -  U.S. Highway
 -  State Highway
 -  Main Roads
 -  Local Roads
 -  15 MPH School Speed Limit (Includes Higher Fine Zone)
 -  Sidewalk
 -  Bike Lanes
- ### Recommendations
-  Proposed Sidewalk

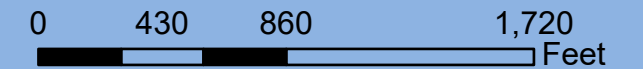

Source: WI DNR, WisDOT, NCWRPC, Village of Weston
This map is neither a legally recorded map nor a survey and is not intended to be used as one. This drawing is a compilation of records, information and data used for reference purposes only. NCWRPC is not responsible for any inaccuracies herein contained.



Prepared By:
**North Central
Wisconsin Regional
Planning Commission**

210 McClellan St., Suite 210, Wausau, WI 54403
715-849-5510 - staff@ncwrpc.org - www.ncwrpc.org

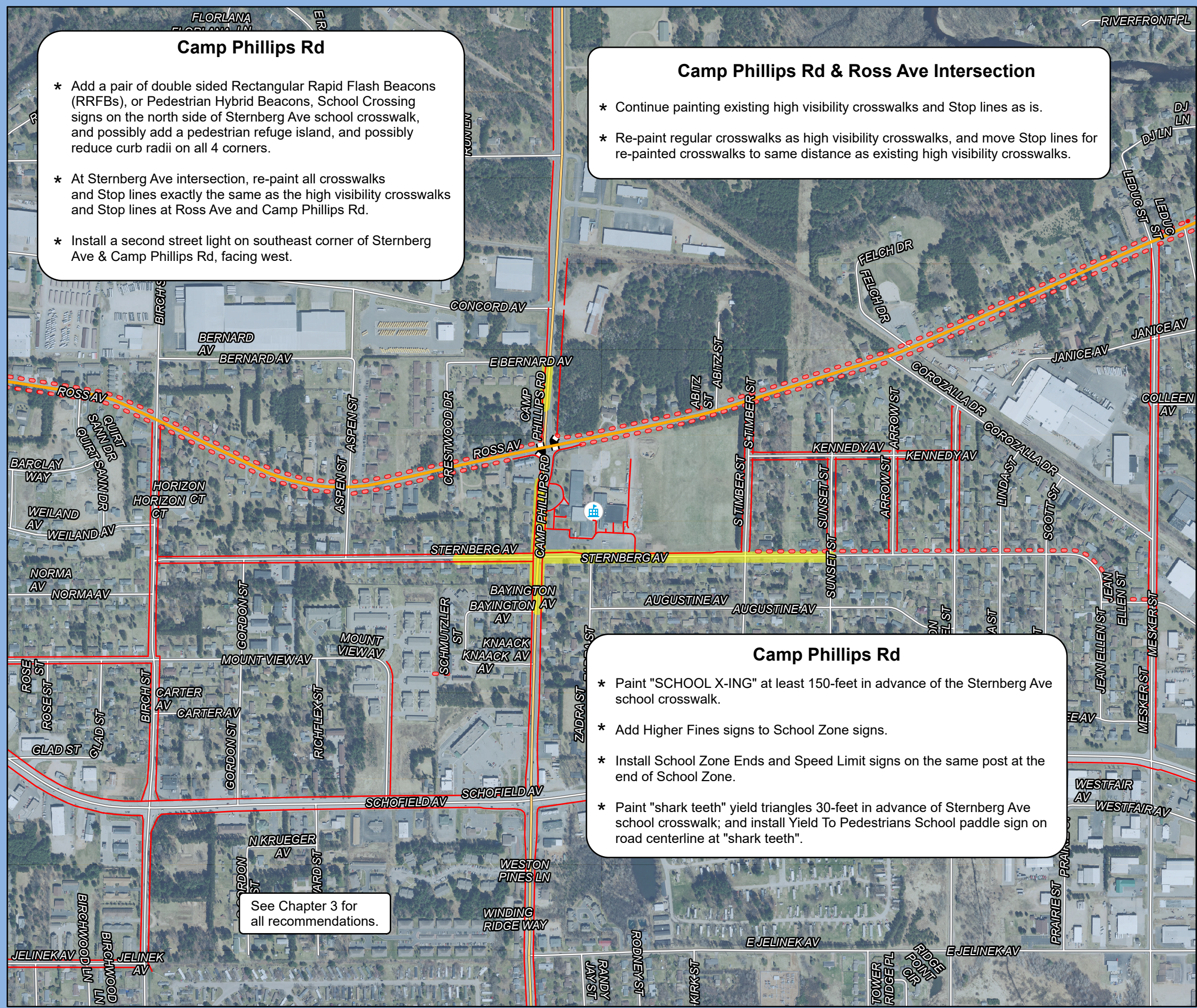

Camp Phillips Rd

- * Add a pair of double sided Rectangular Rapid Flash Beacons (RRFBs), or Pedestrian Hybrid Beacons, School Crossing signs on the north side of Sternberg Ave school crosswalk, and possibly add a pedestrian refuge island, and possibly reduce curb radii on all 4 corners.
- * At Sternberg Ave intersection, re-paint all crosswalks and Stop lines exactly the same as the high visibility crosswalks and Stop lines at Ross Ave and Camp Phillips Rd.
- * Install a second street light on southeast corner of Sternberg Ave & Camp Phillips Rd, facing west.

Camp Phillips Rd & Ross Ave Intersection

- * Continue painting existing high visibility crosswalks and Stop lines as is.
- * Re-paint regular crosswalks as high visibility crosswalks, and move Stop lines for re-painted crosswalks to same distance as existing high visibility crosswalks.

Camp Phillips Rd







- * Paint "SCHOOL X-ING" at least 150-feet in advance of the Sternberg Ave school crosswalk.
- * Add Higher Fines signs to School Zone signs.
- * Install School Zone Ends and Speed Limit signs on the same post at the end of School Zone.
- * Paint "shark teeth" yield triangles 30-feet in advance of Sternberg Ave school crosswalk; and install Yield To Pedestrians School paddle sign on road centerline at "shark teeth".

See Chapter 3 for all recommendations.

Map 6B Physical Recommendations Weston Elementary

Weston Elementary
Safe Routes To School

Legend

-  Weston Elementary
-  Sidewalk
-  15 MPH School Speed Limit (Includes Higher Fine Zone)
-  High Visibility Crosswalk
-  Recommendations
-  Proposed Sidewalk

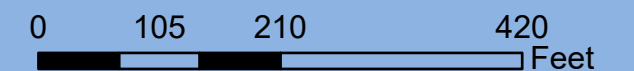

Source: WI DNR, WisDOT, NCWRPC, Village of Weston
This map is neither a legally recorded map nor a survey and is not intended to be used as one. This drawing is a compilation of records, information and data used for reference purposes only. NCWRPC is not responsible for any inaccuracies herein contained.



Prepared By:
**North Central
Wisconsin Regional
Planning Commission**

210 McClellan St., Suite 210, Wausau, WI 54403
715-849-5510 - staff@ncwrpc.org - www.ncwrpc.org

See Chapter 3 for all recommendations.

School Grounds

- * Connect campus sidewalk on south side of building to Camp Phillips Rd sidewalk.
- * Connect campus sidewalk on south side of building through parking lot to Sternberg Ave sidewalk at Zadra St.
- * Install white Stop line 9-feet in advance of Sternberg Ave sidewalk at all three driveways, and move Stop signs back to Stop lines.
- * Replace all bike racks with new racks that allow front tire & bike frame to be locked. As the need arises add scooter racks and skateboard racks. Place at least one new bike rack in an area adjacent to the main entrance.
- * Consider adding a bike repair station by loop drive off of Camp Phillips.

Sternberg Ave & Zadra St Intersection

- * Re-paint regular crosswalk as high visibility crosswalk.
- * Install an in-street Yield to Pedestrians School paddle sign in center of road, 8-feet east of school crosswalk; or, only during arrival and pick-up, place 2 reflective traffic cones in center of road, 8-feet in advance of both sides of school crosswalks on Sternberg Ave.
- * Since no sidewalk exists on south side of Sternberg Ave, then install an in-street Yield to Pedestrians School paddle sign 6-feet off curb face on west side of crosswalk to create pedestrian refuge area in crosswalk.
- * Add a street light to cover crosswalk.

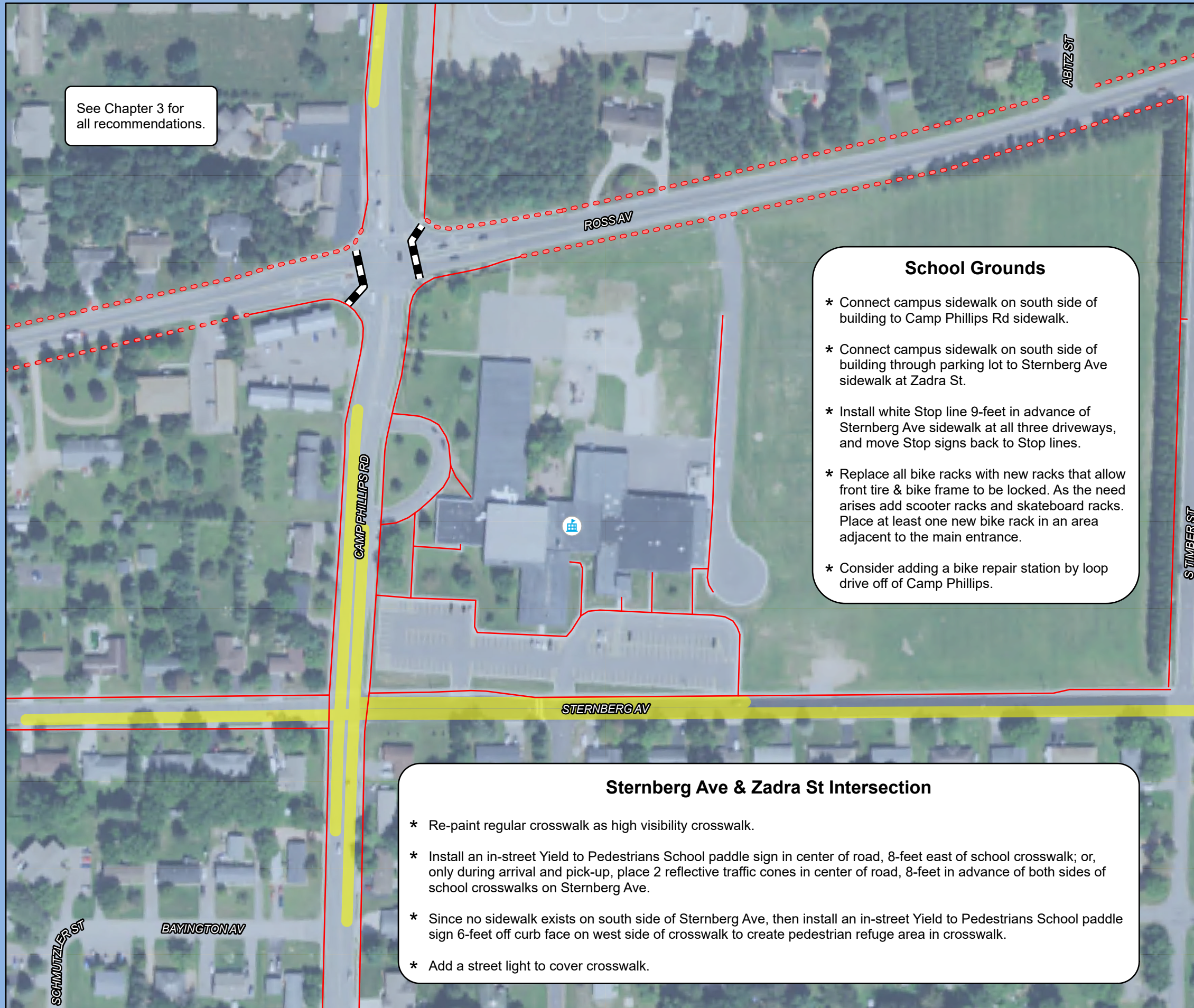

ATTACHMENT A

Student Tally and Parent Survey Forms

From: National Center for Safe Routes to School

- First attachment is the Student Tally.
- Second attachment is the Parent Survey in English
- Third attachment is the Parent Survey in Spanish
- Fourth attachment is the Parent Survey in Hmong

8. Has your child asked you for permission to walk or bike to/from school in the last year? Yes No

9. At what grade would you allow your child to walk or bike to/from school without an adult?

(Select a grade between PK,K,1,2,3...) grade (or) I would not feel comfortable at any grade

Place a clear 'X' inside box. If you make a mistake, fill the entire box, and then mark the correct box

10. What of the following issues affected your decision to not allow your child to walk or bike to/from school? (Select ALL that apply)

11. Would you probably let your child walk or bike to/from school if this problem were changed or improved? (Select one choice per line, mark box with X)

- My child already walks or bikes to/from school (Skip to #12)
- Distance..... Yes No Not Sure
- Convenience of driving..... Yes No Not Sure
- Time..... Yes No Not Sure
- Child's before or after-school activities..... Yes No Not Sure
- Speed of traffic along route..... Yes No Not Sure
- Amount of traffic along route..... Yes No Not Sure
- Adults to walk or bike with..... Yes No Not Sure
- Sidewalks or pathways..... Yes No Not Sure
- Safety of intersections and crossings..... Yes No Not Sure
- Crossing guards..... Yes No Not Sure
- Violence or crime..... Yes No Not Sure
- Weather or climate..... Yes No Not Sure

+ Place a clear 'X' inside box. If you make a mistake, fill the entire box, and then mark the correct box

12. In your opinion, how much does your child's school encourage or discourage walking and biking to/from school?

- Strongly Encourages Encourages Neither Discourages Strongly Discourages

13. How much fun is walking or biking to/from school for your child?

- Very Fun Fun Neutral Boring Very Boring

14. How healthy is walking or biking to/from school for your child?

- Very Healthy Healthy Neutral Unhealthy Very Unhealthy

+ Place a clear 'X' inside box. If you make a mistake, fill the entire box, and then mark the correct box

15. What is the highest grade or year of school you completed?

- Grades 1 through 8 (Elementary) College 1 to 3 years (Some college or technical school)
- Grades 9 through 11 (Some high school) College 4 years or more (College graduate)
- Grade 12 or GED (High school graduate) Prefer not to answer

16. Please provide any additional comments below.

8. ¿En el último año, le ha pedido permiso su hijo para caminar o andar en bicicleta hacia o desde la escuela? Sí No

9. ¿En qué grado permitiría que su hijo camine o ande en bicicleta solo a/o de la escuela? (seleccione un grado entre PK,K,1,2,3...) grado o No me sentiría cómodo/a en ningún grado

¿Cómo llenar este formulario?: Escriba en letras MAYUSCULAS. Marque las cajas con "X"

10. ¿Cuáles de las siguientes situaciones afectaron su decisión de permitir, o no permitir, que su niño camine o ande en bicicleta hacia o desde la escuela? (marque todas las que correspondan)

11. ¿Probablemente dejaría que su hijo caminara o usara la bicicleta para ir a /regresar de la escuela si este problema cambiara o mejorara? (elija una respuesta por línea)

- Distance, Convenience, Time, Activities, Velocity, Quantity, Adults, Sidewalks, Safety, Guards, Violence, Weather. Each item has a 'Yes/No/Not Sure' response grid.

¿Cómo llenar este formulario?: Escriba en letras MAYUSCULAS. Marque las cajas con "X"

12. En su opinión, ¿cuánto apoyo provee la escuela de su hijo a caminar y usar la bicicleta para ir o regresar de la escuela?

- Options: Anima Fuertemente, Anima, Ni uno ni otro, Desalienta, Desalienta Fuertemente.

13. ¿Qué tan DIVERTIDO es caminar o andar en bicicleta hacia o desde la escuela para su niño?

- Options: Muy Divertido, Divertido, Neutral, Aburrido, Muy Aburrido.

14. ¿Qué tan SANO es caminar o andar en bicicleta hacia o desde la escuela para su niño?

- Options: Muy Sano, Sano, Neutral, Malsano, Muy Malsano.

¿Cómo llenar este formulario?: Escriba en letras MAYUSCULAS. Marque las cajas con "X"

15. ¿Cuál es el grado o el año más alto de educación que usted terminó?

- Options: Grados 1 a 8, Grados 9 a 11, Grado 12 o GED, Universidad 1 a 3 años, Universidad 4 años o más, Prefiero no contestar.

16. Por favor proporcione comentarios adicionales:

Empty text box for additional comments.

7. Koj tus menyuam siv sijhawm ntev npaum li cas kom nws mus txog rau lossis los txog tom tsev kawm ntawv? (Xaiv ib qho ntawm txhua kab, khij lub npov nrog tus X)

Sijhawm siv mus los rau tom tsev kawm ntawv

- Tsawg tshaj 5 feeb
- 5 – 10 feeb
- 11 – 20 feeb
- Ntau tshaj 20 feeb
- Tsis paub / Tsis paub tseeb

Sijhawm siv mus los rau tom tsev kawm ntawv

- Tsawg tshaj 5 feeb
- 5 – 10 feeb
- 11 – 20 feeb
- Ntau tshaj 20 feeb
- Tsis paub / Tsis paub tseeb

8. Koj tus menyuam puas tau nug kom koj pub nws taug kev lossis caij luv thij mus/los rau tom tsev kawm ntawv xyoo tag los txog tamsim no? Tau Tsis tau

9. Koj tus menyuam yuav tau nyob qib dabtsi koj thiaj li pub nws taug kev lossis caij luv thij mus/los rau tom tsev kawm ntawv uas tsis muaj ib tug neeg laus nrog?

(Xaiv ib qib uas nyob nruab nrab ntawm PK,K,1,2,3...)

qib

(lossis)

Txawm nws yuav nyob qib twg los kuv yuav tsis pom zoo

10. Vim cov teeb meem twg uas lawv qab ntawm no thiaj li ua rau koj txiav txim tias koj yuav pub, lossis yuav tsis pub, koj tus menyuam taug kev lossis caij luv thij mus/los rau tom tsev kawm ntawv? (Xaiv TAGNRHO cov haum)

11. Yog tias qhov teeb meem no tau hloov lossis raug muab kho kom zoo dua koj puas pub koj tus menyuam taug kev lossis caij luv thij mus/los rau tom tsev kawm ntawv? (Xaiv ib qho rau txhua kab, khij lub npov nrog tus X)

- | | | | |
|---|------------------------------|-----------------------------------|------------------------------------|
| <input type="checkbox"/> Deb..... | <input type="checkbox"/> Pub | <input type="checkbox"/> Tsis pub | <input type="checkbox"/> Tsis Paub |
| <input type="checkbox"/> Yooj yim tsav tsheb dua..... | <input type="checkbox"/> Pub | <input type="checkbox"/> Tsis pub | <input type="checkbox"/> Tsis Paub |
| <input type="checkbox"/> Sijhawm..... | <input type="checkbox"/> Pub | <input type="checkbox"/> Tsis pub | <input type="checkbox"/> Tsis Paub |
| <input type="checkbox"/> Tej yam kev ua si los yog ncaws kis las uas tus menyuam muaj ua ntej thiab tom qab tsev kawm ntawv | <input type="checkbox"/> Pub | <input type="checkbox"/> Tsis pub | <input type="checkbox"/> Tsis Paub |
| <input type="checkbox"/> Txoj kev taug mus muaj tsheb khiav nrawm | <input type="checkbox"/> Pub | <input type="checkbox"/> Tsis pub | <input type="checkbox"/> Tsis Paub |
| <input type="checkbox"/> Txoj kev taug mus muaj tsheb khiav ntau | <input type="checkbox"/> Pub | <input type="checkbox"/> Tsis pub | <input type="checkbox"/> Tsis Paub |
| <input type="checkbox"/> Cov neeg laus los taug kev lossis caij tsheb nrog | <input type="checkbox"/> Pub | <input type="checkbox"/> Tsis pub | <input type="checkbox"/> Tsis Paub |
| <input type="checkbox"/> Cov kev taug ko taw lossis cov kab taug..... | <input type="checkbox"/> Pub | <input type="checkbox"/> Tsis pub | <input type="checkbox"/> Tsis Paub |
| <input type="checkbox"/> Kev nyab xeeb ntawm ob txoj kev sib tshuam thiab qhov chaw hla | <input type="checkbox"/> Pub | <input type="checkbox"/> Tsis pub | <input type="checkbox"/> Tsis Paub |
| <input type="checkbox"/> Cov neeg pab hla kev | <input type="checkbox"/> Pub | <input type="checkbox"/> Tsis pub | <input type="checkbox"/> Tsis Paub |
| <input type="checkbox"/> Kev sib ntaus sib tua lossis kev txob plaub | <input type="checkbox"/> Pub | <input type="checkbox"/> Tsis pub | <input type="checkbox"/> Tsis Paub |
| <input type="checkbox"/> Huab cua lossis huab cua kub txias | <input type="checkbox"/> Pub | <input type="checkbox"/> Tsis pub | <input type="checkbox"/> Tsis Paub |

Kuv tus menyuam yeej taug kev lossis caij luv thij mus/los rau tom tsev kawm ntawv

+	Sau tus 'X' kom pom tseeb rau hauv lub npov. Yog tias koj yuam kev, khij tag nrho lub npov, ces khij lub npov uas thwj	
----------	---	--

12. Raws li koj xav, koj tus menyuam lub tsev kawm ntawv txhawb lossis txhawb kom tsis txhob taug kev thiab caij luv thij mus los rau tom tsev kawm ntawv heev npaum li cas?

- | | | | | |
|---|---------------------------------|--|---|---|
| <input type="checkbox"/> Sib Zog Txhawb | <input type="checkbox"/> Txhawb | <input type="checkbox"/> Tsis Ua Ib Qho Li | <input type="checkbox"/> Txhawb Kom Tsis Txhob Ua | <input type="checkbox"/> Sib Zog Txhawb Kom Tsis Txhob Ua |
|---|---------------------------------|--|---|---|

13. Taug kev lossis caij luv thij mus/los rau tom tsev kawm ntawv lom zem npaum li cas rau koj menyuam?

- | | | | | |
|---------------------------------------|----------------------------------|--|---------------------------------------|--|
| <input type="checkbox"/> Lom Zem Heev | <input type="checkbox"/> Lom Zem | <input type="checkbox"/> Tsis Xav Li Cas | <input type="checkbox"/> Tsis Lom Zem | <input type="checkbox"/> Tsis Lom Zem Kiang Li |
|---------------------------------------|----------------------------------|--|---------------------------------------|--|

14. Thaum koj tus menyuam taug kev lossis caij luv thij mus/los rau tom tsev kawm ntawv nws yuav noj qab haus huv npaum li cas?

- | | | | | |
|--|---|--|--|---|
| <input type="checkbox"/> Noj Qab Haus Huv Heev | <input type="checkbox"/> Noj Qab Haus Huv | <input type="checkbox"/> Tsis Xav Li Cas | <input type="checkbox"/> Tsis Noj Qab Haus Huv | <input type="checkbox"/> Tsis Noj Qab Haus Huv Kiang Li |
|--|---|--|--|---|

+	Sau tus 'X' kom pom tseeb rau hauv lub npov. Yog tias koj yuam kev, khij tag nrho lub npov, ces khij lub npov uas thwj	+
----------	---	----------

15. Koj tau kawm tiav qib lossis mus txog xyoo kawm ntawv siab tshaj li cas?

- | | |
|---|--|
| <input type="checkbox"/> Qib 1 mus txog 8 (Qib qis elementary) | <input type="checkbox"/> Qib siab college 1 mus rau 3 xyoos (Kawm tiav ib co hoob qib siab lossis tom lub tsev kawm ntawv qhia ua haujlwm) |
| <input type="checkbox"/> Qib 9 mus txog 11 (Kawm tiav ib co hoob high school) | <input type="checkbox"/> Qib siab college 4 xyoos lossis siab dua (Kawm tiav qib siab college) |
| <input type="checkbox"/> Qib 12 lossis GED (Kawm tiav high school) | <input type="checkbox"/> Tsis xav teb |

16. Thov sau tej yam koj xav hais ntxiv rau hauv qab.

ATTACHMENT B

Bicycle Crash Analysis for Wisconsin, 2006

From: Wisconsin Department of Transportation

Bicycle Crash Analysis for Wisconsin

Successful efforts have been made over the past three decades in Wisconsin to reduce the number of crashes and fatalities related to bicycle-vehicle crashes. However, a more complete understanding of these crashes was necessary in order to continue to decrease the number of serious and fatal crashes. This comprehensive crash analysis takes the first and most important step of “typing” bike-motor vehicle crashes for 2003. This report goes on to analyze these crashes in more depth and identifies commonalities between these crashes and crash characteristics, specifically related to traffic conditions, roadway attributes, and the users involved in the crashes.

REVIEW OF MAJOR FINDINGS

Based on the preliminary findings of previous smaller studies, some of this study’s findings are not surprising. In another regard, the study produced significant new contributions to crash evaluation in the state. This study made an enormous contribution by determining the crash types for all bicyclist-motorist (bicycle-vehicle) crashes during an entire year. It also researched the characteristics of roadway width in more depth than in previous works. Additionally, the evaluation of sidepath crashes was not done on a statewide basis until this study was performed. Here are the major findings of the report:

- Bicycle-vehicle crashes are declining in the State of Wisconsin. From 1999 – 2004, annual crashes have decreased by 14%. Ideally, this report will contribute to a continual reduction in crashes by increasing bicyclist awareness, providing countermeasures to avoid common crashes, and increasing education amongst bicyclists and motorists.
- Bicycle-vehicle crashes are almost twice as common during workweek days than on the weekend days. The majority of workweek crashes occur during the a.m. and p.m. peak travel hours. The lower number of crashes occurring on weekends may indicate that recreational bike trips occur more frequently on recreational trails or low volume roadways where exposure is less.
- Many bicycle-vehicle crashes had similar characteristics. A large concentration of crashes occurred within one of, or a combination of, the following environments: in an urban city, at an intersection, or on an urban city street or arterial roadway. Eighty-three percent of crashes occurred in a city (MV4000 Report), 93.6% of crashes occurred in an urban area (MV4000 Report), 65.7% of crashes occurred at an intersection (PBCAT), 71.7% of crashes occurred on a city street (MV4000 Report), and 56.1% of crashes occurred on an arterial street.
- Unfortunately, alcohol was a factor in some of the crashes. The MV4000 data does not declare whether the driver or bicyclist was under influence, only if alcohol was a factor in the crash. 4.2% of urban crashes reported alcohol as being involved and 4.6% of rural crashes reported alcohol as being involved. This is slightly lower than national percentages from the Crash Types of the Early 1990’s report and compares to a 7.0% alcohol involvement of all Wisconsin crashes.
- Bicycle-vehicle crashes occurred mainly during daylight hours, and when they did occur at night, most were in a location with lighting. Over 83% of crashes occurred during daylight hours, and of the 12.3% of crashes occurring at night, only one out of every ten occurred without some sort of lighting present.

Bicycle Crash Analysis for Wisconsin

- Male bicyclists were involved in almost 75% of all bicycle – vehicle crashes. Even crashes involving children reported over 70% of the bicyclists being male.
- Almost 80% of rural bicycle–vehicle crashes occurred on roadways with posted speed limits of 55 miles per hour. Crashes occurring at such high rates of speed will increase the likelihood of a bicyclist injury or death. This is evident in the higher percentage of rural crashes resulting in fatalities than in urban crashes.
- Four out of the top five crash types indicate that the motorist made the critical error. This may indicate that motorists are not fully aware of bicyclists on the roadway and that increased education is necessary.
- Urban areas and urban streets have much higher crash rates than rural areas based on all indices examined - miles of roadway, bicycle miles traveled, and vehicle miles traveled. Although crash rates were higher for urban areas, the rate of fatal crashes was double for rural crashes compared to urban crashes based on bicycle miles traveled.
- Milwaukee County has the highest average crash rate when bicycle miles traveled and vehicle miles traveled are averaged together. The rate is three times that of the lowest counties of Brown, Marathon, and Wood.
- The city of Madison has a low average crash rate based on bicycle miles traveled. A scattering of other cities – Appleton, Green Bay, and Wausau also have relatively low average crash rates based on bicycle miles traveled, but none of these communities come close to the total bicycle miles traveled as demonstrated by Madison.
- When bicycle-vehicle crash rate is compared to the overall crash rate for all vehicles, the rate was twice as high for bicycle-vehicle crashes compared to all vehicle crashes. The bicycle crash rate was based on bicycle miles traveled, while the comparison rate for total vehicle crashes was based on total vehicle miles traveled.
- For local rural roads, the greater the width, the lower the bicycle-vehicle crash rate. Twenty foot roadways had a crash rate that was double the crash rate of 22 foot roadways, but the 22 foot roadways had a rate that was over 40% higher than 24' roadways. Overtaking-type crashes were significantly lower for 24' roadways.
- Rural state highways had much lower bicycle-vehicle crash rates than local roads. Similar to local roads, 24-foot roadways had significantly lower crash rates than 22-foot roadways. Interestingly, having three foot paved shoulders did not improve the crash rate among these widths of roadways. However, the crash rate did significantly lessen when five [foot] paved shoulders were added (compared to three foot paved shoulders).
- Sidepath crashes are common crashes in urban areas. Twenty-nine percent of all urban crashes were recorded as such. Motorist drive-out from both sign and signal-controlled intersections are by far the two most common crash types. How significant a problem this is, is difficult to ascertain without knowing the frequency of bicycle use on sidepaths/walks and their connecting crosswalks.

ATTACHMENT C

Highlights of... Wisconsin Pedestrian and Bicycle Crash Analysis: 2011-2013

From: Wisconsin Department of Transportation

Highlights

Overall Trends in Wisconsin Pedestrian and Bicycle Safety

- Higher levels of walking and bicycling were associated with greater pedestrian and bicyclist safety: between 2006 and 2013, the number of people walking and bicycling to work increased and the risk of pedestrian and bicyclist fatalities and injuries (per commuter) decreased.
- Of fatal traffic crashes reported between 2011 and 2013, approximately 10% involved pedestrians and 2% involved bicyclists. Approximately 9% of total trips were made by pedestrians and 1% were made by bicyclists, so these travel modes were overrepresented in fatal crashes.
- The highest concentrations (“hot spots”) of fatal and severe-injury pedestrian and bicycle crashes tend to be along signalized, multilane, arterial roadway corridors in urban and suburban areas with moderate to high levels of pedestrian or bicycle activity. Without controlling for pedestrian and bicycle volumes (or other measures of exposure), it is not possible to determine if these locations experienced more crashes simply because they had more activity or because their conditions were inherently more dangerous. Regardless, these types of locations warrant attention due to high numbers of crashes.

Fatal Pedestrian and Bicycle Crashes

The following points highlight common characteristics of fatal pedestrian and bicycle crashes reported in Wisconsin between 2011 and 2013. Note that these results do not control for exposure: some characteristics may have high percentages of crashes because they are associated with higher levels of pedestrian or bicycle activity.

Fatal Pedestrian Crashes: Location

- 83% were at locations with no traffic signal or stop sign facing the driver (some of these locations had crosswalks, which require motorists to yield the right-of-way to pedestrians).
- 74% were on arterial or collector roadways.
- 55% occurred on roadways between intersections (i.e., >50 feet from the nearest intersection).
- 46% were on roadways with speed limits of 35 mph or higher.
- 36% were on rural roadways.
- 20% were at night on roadways with no lights.

Fatal Pedestrian Crashes: Behavior

- 77% involved a motor vehicle traveling straight.
- 31% involved alcohol (either the driver or the pedestrian had been drinking alcohol).
- 28% involved a driver not yielding to a pedestrian in a crosswalk.
- 65% of fatalities at intersections involved driver error (59% failed to yield to a pedestrian in a crosswalk and 6% violated a traffic signal) while 12% involved pedestrian error (violated a traffic signal).

Fatal Pedestrian Crashes: Other

- 52% occurred between 3 p.m. and midnight. The peak 3-hour period was 3 to 6 p.m. (24%).
- 31% involved pedestrians aged 65 or older.

Fatal Bicycle Crashes: Location

- 76% were on arterial or collector roadways.
- 70% were on roadways with speed limits of 35 mph or higher.

- 67% were at locations with no traffic control for the driver (i.e., no traffic signal or stop sign).
- 64% were on roadways between intersections.
- 33% were on rural roadways.

Fatal Bicycle Crashes: Behavior

- 79% involved a motor vehicle traveling straight.
- 39% involved a motor vehicle striking a bicyclist from behind on a roadway. Of these rear-end fatalities, 62% were on rural highways and 31% occurred during darkness.
- 27% involved alcohol (either the driver or the bicyclist had been drinking alcohol).

Fatal Bicycle Crashes: Other

- Crashes involving bicyclists younger than age 20 decreased from 62% of all bicycle crashes in 2003 to 33% of all bicycle crashes between 2011 and 2013 (includes all injury severity levels).

Strategies to Improve Pedestrian and Bicycle Safety

This report recommends a multi-faceted approach to reduce pedestrian and bicycle crash risk, including engineering, education, enforcement, and evaluation strategies.

Engineering

- Reduce roadway design speeds (e.g., reduce the number of lanes, narrow roadway lanes).
- Reduce roadway crossing distances.
- Provide pedestrian and bicycle facilities (e.g., sidewalks, paved shoulders, and bicycle lanes).
- Improve roadway lighting.

Education

- Increase driver awareness of laws requiring them to yield to pedestrians in crosswalks and provide at least three feet of space when passing bicyclists (even when a bike lane exists).
- Increase driver awareness of the danger they pose to their neighbors who are walking and bicycling when they speed, are intoxicated, or are distracted (e.g., texting while driving, eating).
- Increase driver awareness of their responsibility to travel at a prudent speed (potentially lower than the speed limit) in order to be able to react safely to pedestrians and bicyclists at night.
- Increase bicyclist awareness of the risk of riding in the opposite direction of adjacent traffic, disobeying traffic control, and bicycling at night without lights and bright clothing.
- Increase pedestrian awareness of the risk of walking while intoxicated and disobeying traffic control. Emphasize the importance of pedestrian nighttime visibility to aid driver detection.

Enforcement

- Enforce laws to reduce drunk driving, speeding, failure to yield to pedestrians, and passing too close to bicyclists
- Enforce laws to reduce bicycling at night without lights and pedestrian and bicyclist traffic signal violations.

Evaluation

- Improve police pedestrian and bicycle crash reporting practices to record details such as alcohol involvement by person/individual, crash type, helmet use, use of lights, and relevant maintenance problems.
- Collect pedestrian and bicycle counts and surveys to account for exposure.
- Quantify the impacts of specific intersection and roadway characteristics, education, and enforcement efforts on pedestrian and bicycle crash risk to inform future recommendations.

ATTACHMENT D

Adoption Documentation

From: Various governing bodies

VILLAGE OF WESTON, WISCONSIN
RESOLUTION NO. 2024-006

A RESOLUTION, Adopting the Weston Elementary Safe Routes to School Plan

WHEREAS, the Village of Weston, Marathon County, supports improving walking and biking routes for students to get to school; and

WHEREAS, the health and safety of children is of highest concern to the citizens of the Village of Weston; and

WHEREAS Safe Routes to School (SRTS) efforts help remove barriers to walking and biking to school, and reduce traffic congestion and speed in and around schools; and

WHEREAS the Wisconsin Department of Transportation (WisDOT) requires, that in order to be eligible for funding of needed projects, municipalities need to either create or amend their SRTS Plan; and

WHEREAS, the Village of Weston has developed a SRTS Plan for the dual purposes of serving as a guide for future programming and infrastructure improvements (the 6 E's of education, encouragement, engineering, equity, enforcement and evaluation), and in order to be eligible for various funding programs including WisDOT's Transportation Alternatives Program (TAP grant); and

WHEREAS, the Village of Weston had staff on the SRTS Task Force; and

WHEREAS, the SRTS Task Force collected data, reviewed the results, and provided direction for SRTS Plan development, and then incorporated those results into the SRTS Plan.

NOW THEREFORE, BE IT RESOLVED, that the Village of Weston hereby adopts Resolution 2024-006

BE IT FURTHER RESOLVED, that the Village of Weston staff is directed to begin implementing this SRTS Plan by coordinating efforts among both entities who created this plan (Village of Weston and Weston Elementary)

PASSED BY THE BOARD OF TRUSTEES OF THE VILLAGE OF WESTON, at a meeting thereof this 18th day of the month of March, 2024.

VILLAGE OF WESTON, a Municipal Corporation of the State of Wisconsin.

By: 
MARK MALONEY, President

ATTEST:
By: 
PAMELA BREHM, Clerk



Regular School Board Meeting
Wednesday, August 21, 2024, 6:30 PM Central
D.C. Everest Administration Building
6100 Alderson Street
Weston, WI 54476



I. Call to Order

Meeting was called to order at 6:30 p.m. by Vice President Felch

II. Roll Call

Joshua Dickerson: Present via phone, Katie Felch: Present, Shannon Grabko: Present, Lindsey Lewitzke: Absent, Larry Schaefer: Present, Yee Leng Xiong: Present. Present: 6, Absent: 1

III. Pledge of Allegiance

IV. Approval of Agenda

Motion to approve the agenda for tonight's meeting. With a voice vote, this motion, made by Yee Leng Xiong and seconded by Shannon Grabko, passed.

V. Public Comment

Gayle Marshall, 4503 Estate Drive, Weston, WI 54476 taxpayer, Title IX

James Juedes, E2323534 Pleasant View Rd., Easton, Title IX

VI. Consent Agenda

Motion to approve the Consent Agenda. This motion, made by Larry Schaefer and seconded by Yee Leng Xiong, passed with a roll call vote.

Lindsey Lewitzke: Absent, Ben Bliven: Yea, Joshua Dickerson: Yea, Katie Felch: Yea, Shannon Grabko: Yea, Larry Schaefer: Yea, Yee Leng Xiong: Yea
Yea: 6, Nay: 0, Absent: 1

VI.A. Approval of Minutes

VI.A.1. Minutes of July 31, 2024, Special Meeting

VI.A.2. Minutes of July 17, 2024, Regular Meeting

VI.B. Recommended Employment/Resignations/Contract Adjustments

VI.C. Treasurer's Report - General/Other Fund Bills

VI.D. Balance Sheet

VI.E. Budget Transfers - None

VI.F. Budget Revisions - None

VI.G. Grant Application(s)/Budget(s) Approval

VI.H. Fundraising Requests

VI.I. Gift/Bequests

VI.J. Bus Accident Report

VI.K. Second Reading of Policy

VII. Reports/Considerations

VII.A. WASB Legislative Network Member

VII.B. CESA #9 Representative

VII.C. Superintendent

VII.C.1. District Update

VII.C.2. Insurance Renewal

VII.C.3. Board Workshop

VII.C.4. Student Advisory

VII.C.5. Kick Off August 29 at 11:00 a.m. at GTCC

VII.C.6. Homecoming, Friday, Sept. 27, 2024, Parade line up by 5:00 at Senior High parking lot, game at 7:00 p.m.

VIII. New Business

VIII.A. Weston Safe Routes to Schools Plan

Motion to approve the Safe Routes to Schools Plan as attached in the background. With a voice vote, this motion, made by Joshua Dickerson and seconded by Larry Schaefer, passed.

VIII.B. Ten Year Capital Projects Plan

Motion to approve the Ten Year Capital Projects Plan as attached in your background. This motion, made by Yee Leng Xiong and seconded by Shannon Grabko, passed with a voice vote.

VIII.C. Staff Accident Insurance

Motion to approve the staff accident insurance as outlined in the background memo. With a voice vote, this motion, made by Larry Schaefer and seconded by Ben Bliven, passed.

VIII.D. Summer Learning Report

VIII.E. Odyssey Handbook for Approval

Motion to approve the Odyssey Handbook for 2024-2025. With a voice vote, this motion, made by Shannon Grabko and seconded by Ben Bliven, passed.

VIII.F. At-Risk Report po6830

VIII.G. Approval of School Safety Booklets

Motion to approve the school safety booklet as attached in the background. With a voice vote, this motion, made by Yee Leng Xiong and seconded by Shannon Grabko, passed.

VIII.H. Approve Access to Student Records for School Resource Officers

Motion to approve access to student records for our 2024-2025 School Resource Officers.
With a voice vote, this motion, made by Larry Schaefer and seconded by Ben Bliven, passed.

VIII.I. Resolution to Adopt Title IX Policies po2266 and po2264

Motion for a resolution to adopt po2264 and po2266 with acknowledgement that any court order could modify or nullify either of them made by Larry Schaefer and seconded by Ben Bliven. With a roll call vote: Lindsey Lewitzke: Absent, Ben Bliven: Yea, Joshua Dickerson: Yea, Katie Felch: Yea, Shannon Grabko: Nay, Larry Schaefer: Yea, Yee Leng Xiong: Yea
Yea: 5, Nay: 1, Absent: 1

Amendment to the resolution to adopt both po 2264 and po2266 that the Board will have a 30-day time limit to review this resolution if the court ruling contradicts the current policies made by Xiong and seconded by Schaefer. With a roll call vote: Lindsey Lewitzke: Absent, Ben Bliven: Yea, Joshua Dickerson: Yea, Katie Felch: Yea, Shannon Grabko: Nay, Larry Schaefer: Yea, Yee Leng Xiong: Yea
Yea: 5, Nay: 1, Absent: 1

VIII.J. First Reading of Policy 5830 - Student Fund-Raising

Motion made by Joshua Dickerson and seconded by Shannon Grabko to approve po5830 on first reading. With a voice vote, this motion passed.

VIII.K. Set a Board Workshop Date - Suggested dates are: October 28, 29 or 30, and November 12 or 13. November 13 at 5:00 was chosen.

IX. Petitions and Communications

X. Future Meeting Dates

X.A. Regular Board Meeting
Wednesday, August 21, 2024, at 6:30 p.m.
D.C. Everest Administration Building
6100 Alderson Street
Weston, WI 54476

Training for WASB Superintendent Evaluation Program
Wednesday, Sept. 18, 2024, at 5:00 p.m.
D.C. Everest Administration Building
6100 Alderson Street
Weston, WI 54476

Regular Board Meeting
Wednesday, Sept. 18, 2024, at 6:30 p.m.
D.C. Everest Administration Building
6100 Alderson Street
Weston, WI 54476

WASB Regional Meeting/Workshop
October 1, 2024, at 6:00 Registration/Networking
Holiday Inn & Suites
1000 Imperial Ave.

Rothschild, WI 54474
(Please register through Ellen)

Annual Meeting/Budget Hearing
Tuesday, October 22, 2024, at 6:00 p.m.
D.C. Everest Senior High Auditorium
6500 Alderson Street
Weston, WI 54476

Regular Board Meeting
October 22, 2024, immediately following the Annual Meeting/Budget Hearing
D.C. Everest Administration Building
6100 Alderson Street
Weston, WI 54476

November Board Workshop
TBD
D.C. Everest Administration Building
6100 Alderson Street
Weston, WI 54476

Regular Board Meeting
November 20, 2024, at 6:30 p.m.
D.C. Everest Administration Building
6100 Alderson Street
Weston, WI 54476

XI. Motion to adjourn by Schaefer, second by Bliven at 7:55 p.m.

Respectfully submitted,

Shannon E. Grabko, Clerk

Ellen Suckow, Executive Assistant to the
Superintendent & School Board

PLEASE NOTE: These minutes are not the official minutes of the School Board until they are approved at the September 18, 2024, meeting of the School Board.

ATTACHMENT E

Bicycle Parking Guidelines

From: Association of Pedestrian and Bicycle Professionals (APBP)
One page summary sheet.

And from City of Baltimore

Bicycle Parking Guidelines

A summary of recommendations from the Association of Pedestrian and Bicycle Professionals

Bicycle Parking Design

- Required spaces shall be at least 2 feet by 6 feet.
- An access aisle of at least 5 feet shall be provided in each facility.
- Racks shall be situated to allow a minimum of 2 feet between adjacent bike parking stalls.
- Spaces shall have a vertical clearance of at least 80 inches.

Bicycle Rack Design

Structures that require a user-supplied locking device:

- must accommodate U-shaped locking devices;
- support the bike frame at two points;
- be securely anchored to the ground or the building structure; and
- be designed and maintained to be mud and dust free.

Bicycle Rack Location

- Racks should be located in a clearly designated safe and convenient location.
- Racks should be designed and located to be harmonious with the surrounding environment.
- Racks should be at least as convenient as the majority of auto parking spaces provided.

To learn more about bicycle parking guidelines, visit the Association of Pedestrian and Bicycle Professionals at: www.apbp.org.

These bicycle racks do NOT meet the design guidelines:

Grid or Fence Style Racks



Wave or Ribbon Style Racks



These bicycle racks DO meet the design guidelines:

Inverted-U Style Racks



Angled Wave Style Racks



Freestanding Style Racks



The above images are examples only. NCWRPC does not endorse any particular bicycle rack manufacturers.

If you have questions about whether a particular bicycle parking rack you are considering using meets these requirements, please contact NCWRPC planner **Fred Heider**, AICP at fheider@ncwrpc.org.

PLACEMENT OF BICYCLE PARKING RACKS

RACK PLACEMENT

RULES:

5' from:

Fire hydrant
Crosswalk

4' from:

Loading zone
Bus stop
Bus shelter
Bus bench

Min. 2', Rec. 3' from:

Curb

3' from:

Parking meter
Newspaper rack
US mailbox
Light pole
Sign pole
Driveway
Tree space
Trash can
Other street furniture
Other sidewalk obstructions

WALL SETBACKS

For racks set parallel to a wall:
Min. 24", Rec. 36"

For racks set perpendicular to a wall:
Min. 28", Rec. 36"

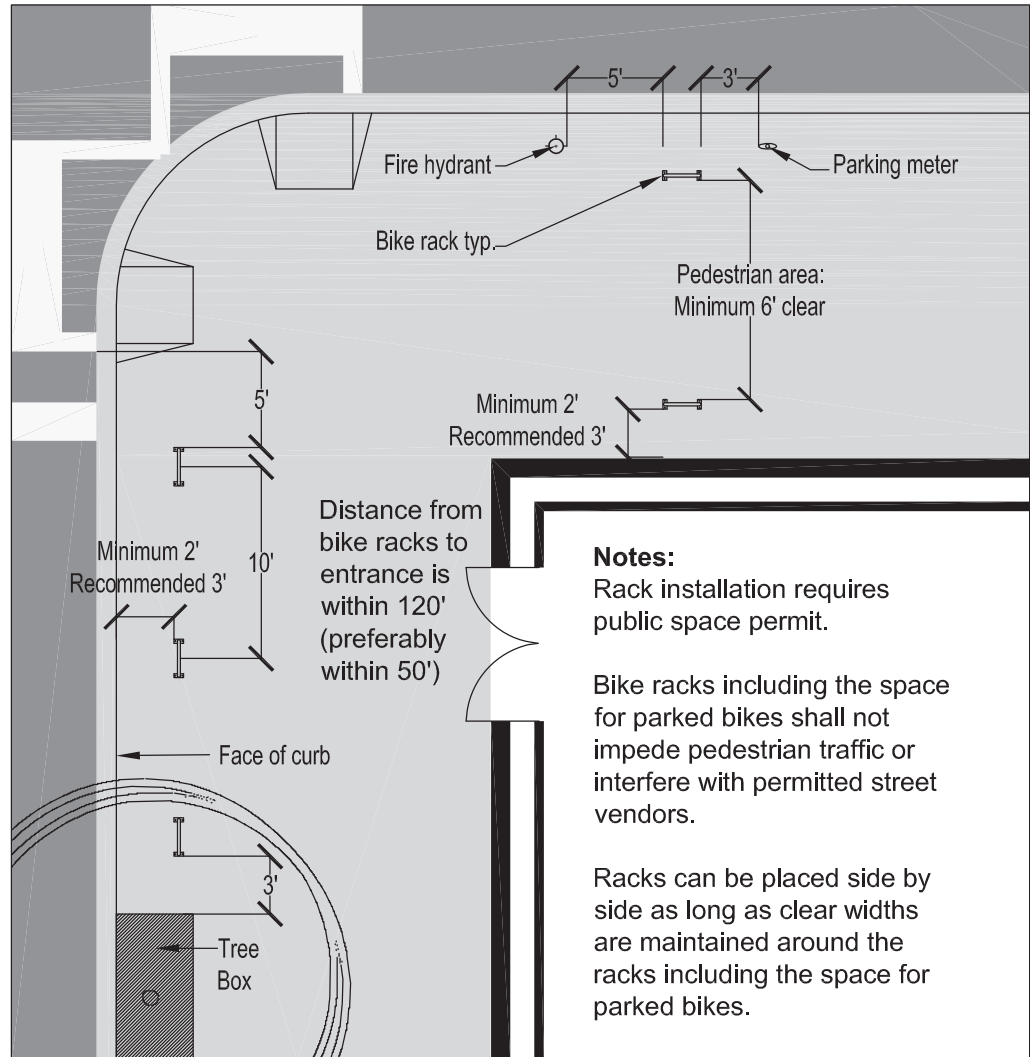

SCALE 1" = 10'

SIDE VIEW

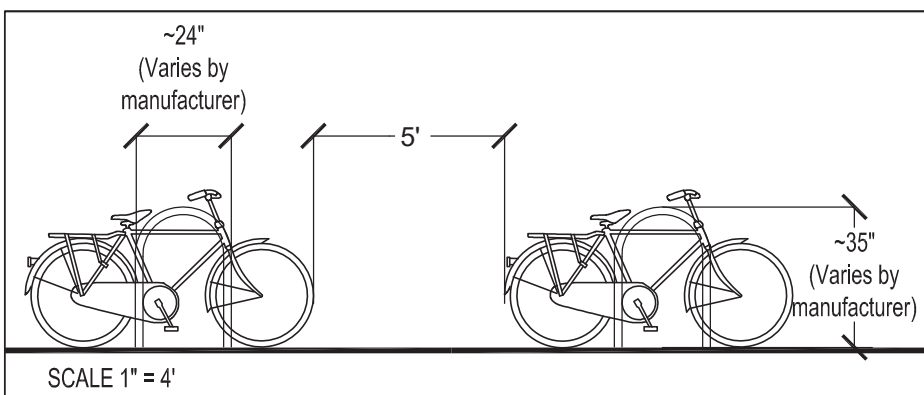

SIDE BY SIDE RACKS:

